DOI: <https://doi.org/10.53555/eijse.v3i3.87>

POLAR PLOTS OF A DIRECTIONAL MICROPHONE WITH REAL-WORLD SOUNDS AND ITS SPECTRUM DISTORTION

Xubao Zhang PhD^{1*}

¹*Engineer, R & D, Unitron Canada, Sonova, Switzerland; Associate Professor, EE Department, Xi'an Electronic Science and Technology University, China. 519-2796319,*

***Corresponding author:**

Email: xbzwdl@yahoo.com.

Abstract:-

Some references discussed and evaluated performances of conventional directional microphones in hearing aids, from their conclusions, it is undoubted for the microphones to improve S/N, yet conditions of the advantage somewhat confused to hearing aid clinicians and professionals. To supplement the incompleteness, we investigated behaviors of a directional microphone in extensive situations. We built an SimuLink laboratory, selected realistic talking voices and noises from wave files and made many experiments to find out illustrative evidences. Electroacoustic models are used for components of modelling a directional microphone; we operated the microphone with these sounds from real-world to calculate, view, measure and record behaviors of the directional microphone. We acquired many waveforms, statistics and recordings of the experiments with woman's and man's talking voices, and environmental noises; we also listened to sounds at input and output of the directional microphone to perceive changes of the speech naturalness.

Comparing to an omni microphone, the directional microphone does not enhance the speech signals on average; sensitivity-gain of the directional microphone is higher than that of the omni microphone when the tone frequency > 1.78 kHz; the directional microphone cancels the undesired speech well, as well as the babble noise and the environmental white noise from a beamed source at rear side; the directional microphone cannot improve the S/N of a speech within babble or white noise fields; in addition, we also observed and heard the speech spectrum distortion caused by the directional microphone.

Keywords:- Directional microphones, sensitivity-gain, spectrum distortion, hearing aids, wave files, SimuLink

1. INTRODUCTION

A directional microphone (DM) gives more benefits than other processing strategies in a hearing aid [1,2], so hearing aid users and manufacturers are interested in it. For many years, all the hearing aid manufacturers have applied various DMs to their products. Flynn [3] designed a voice-priority system with tri-pattern beamformer of parallel processing, such an adaptive processor can make reliable decision on varying environment and can implement the optimal DM mode. Chalupper, et al. [4] developed a soft-level DM technique and incorporated it into the common multi-channel DM system, such a system can improve S/N of the DM in soft-level noise situation. Nyffeler, et al. [5] designed a practical control of beam-form modes, which can focus the beam-form on corresponding direction whenever speech is coming from the rear, left or right side. However, some references reported after their verification that performances of DMs are not so optimistic. Gnewikow, et al. [6] spent 3 years for investigating effectiveness of the DMs on 94 subjects, and they concluded that those directional hearing aids exhibited better performance for objective speech-in-noise measurement in the laboratory, but a not clear advantage for subjective measurement in environments. Bentler [7] studied the DM evaluation based on 9-article review, and concluded that those evidences provided weakly supported effectiveness of the DMs; she encouraged the careful consideration of methodologies for assessing. Wu, et al. [8] investigated three modern hearing aids with DMs, and their results show that those new DM technologies benefit signal-to-noise ratio (S/N) of the hearing aids, yet the conventional DMs are not advanced in a driving van on highway in comparison to omni Mic. Failure to adequately analyze and measure the DMs in realistic situations may result in an overprediction of their benefit and misleading developments of new DMs.

Most polar plot analyses and measurements in optimistic references are based on pure tone sources, the obtained DM patterns have the stunning directivity under some conditions, but the results with pure tones cannot ensure the same effects on talking voices and realistic noises. We also measured many DM hearing aids, and their equivalent input noise levels in directional mode are much higher than those in omni mode. How the conventional DMs behave with different effects on cancelling various interferences, such as undesired speeches, party babble noises, fan white noises, etc. is one of our concerns. Secondly, Phonak [9] described that sensitivity response of a double-Mic DM declines by 6dB/Octave at low-mid frequencies. Whether such a sensitivity response can maintain naturalness of target speeches is another of our concerns. After acquiring extensive evidences, we attempt to answer these crucial questions. Playingback of sounds recorded in real-world to a DM can reliably verify advantages and disadvantages of it. We collected many sound wave files which were recorded in the real-world, and modeled cardioid microphone (Mic) and supercardioid Mic in our SimuLink laboratory; there test instruments, such as Time Scopes, FFT Scopes, and various processing resources are available and powerful. Through getting insight into various behaviors of the modelling DMs, such as polar plots, sensitivity-gain responses vs. ports spacing, and waveforms, statistics and spectra at test points of the DM, we found extensive evidences for evaluating, e.g. conditions of improving S/N with the DM, speech spectrum distortion caused by the DMs, etc. This article will describe the analysis, studies, methods, evidences and evaluations of the cardioid Mic, as well as procedures to achieve our experiments, including recruiting and operating the selected wave files in Appendix at the end. Such digital experiment results should be the same as obtained on a breadboard.

2. Spatial behaviors of a cardioid microphone in real-world sound fields

When two omni Mics combine with a time delay and a subtractor as in Fig.1, they form a simple sound beamformer, i.e. well-known conventional directional microphone. In Fig.1, the solid arrows represent the 0° (front) incidence and the dashed arrows represent the non-zero degree incidence. Without losing generality, sensitivities of the omni Mics are assigned to be 1 (0dB) and A/D converters are ignored. In the case that coming

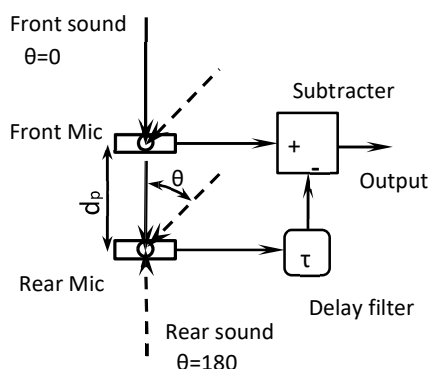

Fig. 1 Basic architecture of a conventional directional Mic

sounds are pure tones, assume output of the front Mic is $y_f(t) = \sin(2\pi ft)$, f is frequency and t is time, then output of the rear Mic is $y_r(t) = y_f(t - \delta(\theta))$, $\delta(\theta)$ is external time delay from the front Mic port to the rear Mic port, depending on d_p spacing between the two ports and incident angle θ . $\delta(\theta)$ can be calculated by $\delta(\theta) = \Delta \cos(\theta)$, the ports spacing delay $\Delta = d_p/v_s$, v_s sound propagation velocity in air. A delay filter is put in output circuit of the rear Mic, its parameter τ is called

internal time delay, which can control pattern shape of the DM. After subtracting the filter output from the front Mic output, the DM output is obtained:

$$y_{dm}(t) = \frac{\sin(2\pi ft) - \sin[2\pi f(t - \delta(\theta) - \tau)]}{\pi f(\tau + \delta(\theta))} = 2\sin[\pi f(\tau + \delta(\theta))] \cos[2\pi ft - \pi f(\tau + \delta(\theta))] \quad (1)$$

We can see that the DM output still is a tone signal and has an amplitude $2\sin[\pi f(\tau + \delta(\theta))]$ and an additional phase $-\pi f(\tau + \delta(\theta))$. Obviously, the output is related to time, frequency, ports spacing, filter delay and incident angle. As for spatial behavior of the DM, we need to discuss its gain. For convenience, we define $\frac{DM \text{ sensitivity}}{omni \text{ Mic sensitivity}}$ as sensitivity(S)region. The outer one results from 5kHz tone, having front (max) gain 2(6dB) at 0°; the inner one, from 500Hz tone, having front gain 0.292(-10.7dB). The lower the frequency is, the less the gain is; yet most of open references show gain pattern of the cardioid Mic at 5kHz only.

2.2 In a voice field

A speech is very dynamic sound of time-varying spectrum [10], its spectrum occupies the entire audio gain of the DM. Based on the above assumptions, we frequency region. We cannot derive an equation for can derive that the S-gain= DM output/ omni Mic output. speech to calculate the S-gain pattern as in (3); we have We prefer a real-person voice to a synthesised speech for which is related to frequency, ports spacing and incident angle. The DM of Fig.1 is a conventional cardioid Mic when τ is equal to Δ . Assuming $d_p=16\text{mm}$ or $\Delta=0.04662\text{ms}$, we can discuss spatial behaviors of a typical cardioid Mic as follows.

2.1 In a pure tone field

Pure tones are sounds of impulse autocorrelation and line spectrum. From (2), S-gain of a conventional cardioid Mic is assessing DM behaviors. In our SimuLink laboratory, we selected realistic woman's voice "speech" from a wave file [11], its recording parameters are duration 0.533s, sampling rate 44.1kHz, word size 16bits. By measuring the DM, we obtained a S-gain pattern of 8 incident angles at intervals of 45°, then interpolated between these obtained gain data to get totally 16 points for smoothing the pattern, shown in Fig.3. There we can see that the pattern shape still is Given τ , the S-gain of the DM in Fig.1 is to measure outputs of the cardioid Mic with voice inputs. $g_{dm}(\theta, f) = 2 \sin[\pi f(\tau + \Delta \cos(\theta))]$ (2)

$$g_c(\theta, f) = 2\sin[\pi f\Delta(1 + \cos(\theta))] \quad (3)$$

Fig.2 shows that S-gain patterns of the cardioid Mic with tones, which result from 3 tone frequencies 5k, 2k and 500Hz, respectively. Each pattern has a zero notch

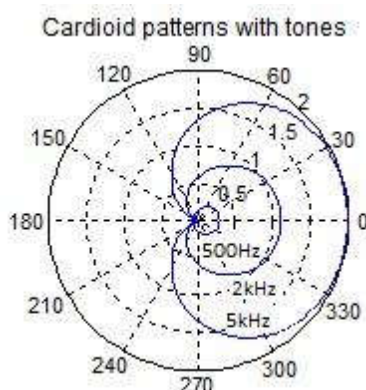

Fig. 2 Gain patterns of cardioid Mic with pure tones

at incident 180°. In hearing aid measurement, we used 5kHz pure tone to represent high frequency region; 2kHz, mid frequency region; and 500Hz, low frequency

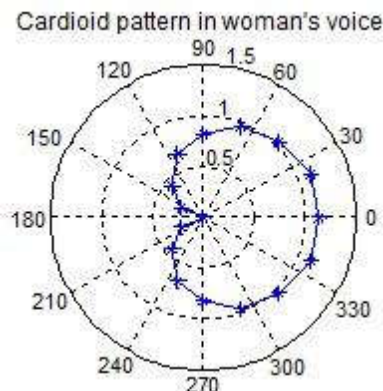

Fig. 3 Gain pattern of cardioid Mic in woman's voice

close to a cardioid curve, and front gain of the cardioid Mic with the voice is 1.14 (1.14dB), less than the max gain with 5kHz in Fig.2, about average of the front gains of the three tones. For details of the waveforms, statistics and procedures in this DM experiment, see Appendix at the end. Fig.4 shows S-gain pattern of the cardioid Mic with

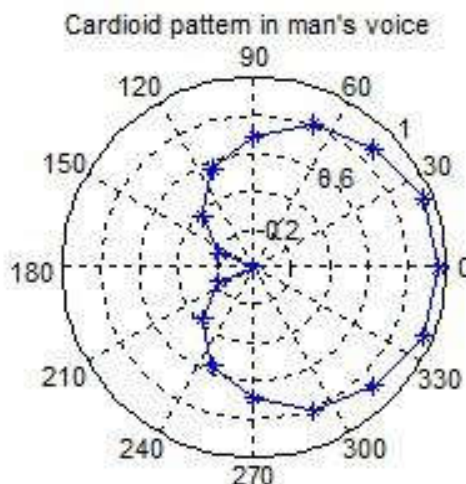

Fig. 4 Gain pattern of cardioid Mic in man’s voice

a man’s voice “voices”, which results from a wave file [11], of the parameters 0.641s, 44.1kHz, 16bits. We can see that the gain pattern has front gain 0.967(- 0.29dB), which is less than that with woman’s voice. We tested and compared spectra of the two voices, the energy of man’s spectrum is larger at low frequencies than that of woman’s spectrum, so difference between the patterns in Fig. 3 and Fig. 4 is reasonable. For details of this voices

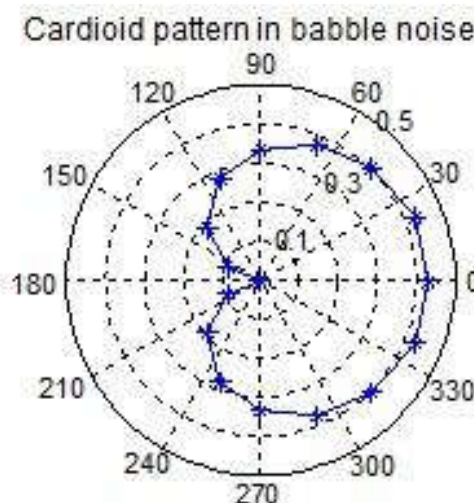

Fig. 5 Gain pattern of cardioid Mic in babble noise

entire frequency region and of impulse autocorrelation at lag=0; another is non-ideal white noises, weakly correlated, e.g. ceiling fan noise [14]. Theoretically, in an ideal white noise, power of the DM output is summation of the powers of the front and rear Mics outputs; and Sgain pattern of the cardioid Mic with the white noise is a circle curve of gain $\sqrt{2}$ (3dB), except a zero notch at 180 experiment, see Appendix at the . We selected two corresponding white noise wave files [14,15]. S-gain pattern of the ideal noise is outer one 2.3 In a babble noise field shown in Fig.6, close to a The babble noise typically is a combination of multi talkers’ sounds in a party; it is a complex signal and its spectrum occupies the entire audio frequency region; hearing patients describe it as competing noise. The babble noise which we selected was recorded with 9person continuously talking in a party[12], of the parameters 0.227s, 44.1kHz, 16bits. In our laboratory, we measured S-gain pattern with 8 angles; then we interpolated as in the voice patterns, and got totally 16point pattern, shown in Fig.5. We can see that its front gain is 0.43 (-7.3dB). We tested spectrum of the babble noise, which is similar to that spectrum provided by Mahendru, et al. [13], spectral energy is more at low frequencies than at high frequencies. For details of this babble experiment, see Appendix at the end.

2.3 In a white noise field

Roughly, white noises include two classes: one is ideal white noise, e.g. device thermal noise, it is uncorrelated, continuous noise, of flat spectrum in the

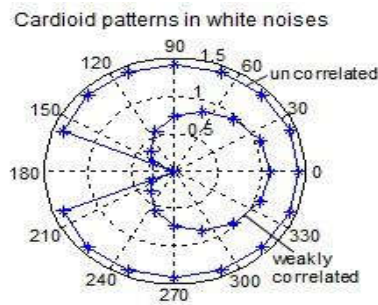

Fig. 6 Gain patterns of cardioid Mic in white noises

circle curve, gain about 1.41, so we can say that the DM in a white noise field has no directivity. Pattern of the non-ideal noise is a cardioid curve, inner one shown in Fig. 6 too. The wave files of the two white noises are of the parameters 0.227s, 44.1kHz, 16bits. For details of these white noise experiments, see Appendix at the end. The polar patterns of the 3 pure tones in Fig.2 have undesired tones from rear side very well. However, the gain patterns of the cardioid Mic significantly lessen while frequencies of the tones decrease. So, the DM is satisfactory with improving S/N of tones under some conditions, not in general sense. The patterns in Fig.3 to Fig.6 tell us that the front gains of the cardioid Mic with voices are about 1(0dB), i.e. the DM cannot enhance speeches more than omni Mic; thus, S/N improvement relies only on cancelling noise, especially depending on site and size of the noise source, i.e. ensuring that the noise is beamed and coming around 180°; when a speech is within babble or white noise field, it is impossible to improve S/N.

3. S-gain frequency response of a cardioid microphone

In Fig.2, we have seen that the smallest pattern (500Hz) of the cardioid Mic has negative gain, -10.7dB at 0°, thus, it is a challenge to enhance speech. What approach can improve the gain of the cardioid Mic? We assigned three different sizes of ports spacing: 20mm, 16mm and 12mm, and calculated these gain responses by means of (3). Fig. 7 shows three S-gain responses of the cardioid Mic with the spacing sizes at incident 0°, and S-gain response of an omni Mic is there too. We can see that the response curve of spacing 16mm shows gain 0~ 6dB at the frequencies >1.78kHz, and negative gain -18~0dB, at the frequencies <1.78kHz. This fact tells us that when frequency is less than 1.78kHz, speech enhancement of the DM is not good as that of omni Mic. When the spacing increases from 12 to 16mm, the gain curve mostly shifts up, about 2dB up; from 16 to 20mm, about 1.5dB up. The frequencies at which the DM gain curves cross over the omni gain curve go down from 2.41 to 1.78 to 1.44kHz; but slopes of the gain curves do not change, declining about 6dB/octave. For a common hearing aid, we cannot find room on it to fit the ports spacing longer than 20mm. Thus, the cardioid Mic has no good gain responses although it has good directivity. A common hearing aid has multi-

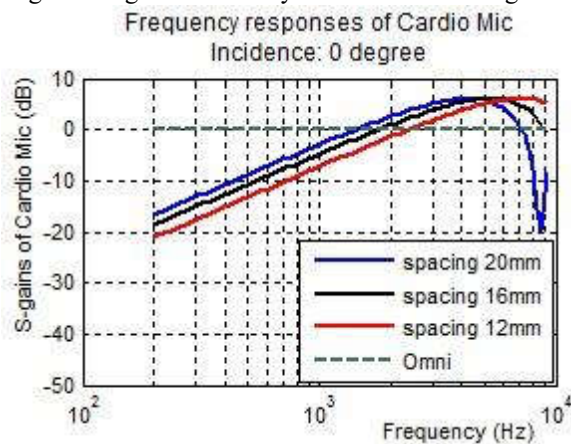

Fig. 7 S-Gain frequency responses of cardioid Mics with three sizes of ports spacing

channel processing; currently the DM processing can balance/flat the overall frequency response of the hearing aid by reducing gains of the high frequency channels or by increasing gains of the low frequency channels, but such a processing strategy always cause adverse S/N. Instead of simply adjusting the gains, a DM processor which can balance overall frequency response but does not drop the S/N must have a different architecture from the conventional DM.

In Fig.7, when the frequency keeps increasing, the gain curves will be going down at some frequencies; so, there exists a frequency which makes the gain curves rise to a summit, called the summit frequency the optimal frequency of the DM gain. Physically, at the optimal frequency, tones from the front and rear Mics are added in phase; mathematically, the optimal frequency is equal to $1/(4\Delta)$, i.e. depending on the ports spacing only. Table 1 lists relationship between the ports spacing, spacing delay and optimal frequency of the cardioid Mics.

Table 1 Ports spacing, spacing delay, optimal frequency of cardioid Mics

ports spacing	spacing delay	optimal frequency
20mm	0.0000583s	4288Hz
16mm	0.0000466s	5363Hz
12mm	0.0000350s	7151Hz

4. Spectrum distortion of a cardioid microphone in talking voices

In Fig.7, we have concerned the S-gain frequency response of the cardioid Mic. When the voice signals go through the cardioid Mic, how does voice naturalness change? Or does the cardioid Mic cause distortion? For answering, we selected voices from wave files of a woman’s and a man’s talking in real-world [11].

Selected woman’s talking “voices” contains 4 phones *voi_c_e_s*; we can view its waveform by means of Adobe Sound Booth or Time Scope in our laboratory. When /voices/ enters the cardioid Mic, the entire /voices/ lasts 0.641s, waveform of the front/ rear Mic output is shown in Fig. 8 (a). Durations of /voi/, /c/, /e/, /s/ are about 0.26, 0.1, 0.16 and 0.12s, respectively.

At the cardioid Mic output, we measured and recorded the waveform, shown in Fig. 8 (b). Comparing (a) to (b), we can see that levels of /voi/ and /e/ are declined significantly, but levels of /c/ and /s/ are enhanced significantly. Table 2 lists peak-peak and root-mean-square (RMS) values of the phones, *voi_c_e_s*. We

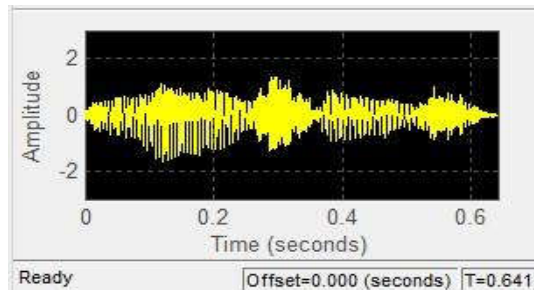

(a) Waveform of the front/rear Mic output “voices”

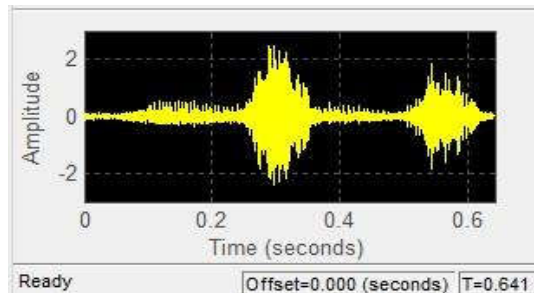

(b) Waveform of the cardioid Mic output “voices”

Fig. 8 Waveforms of woman’s talking “voices” at test points of cardioid Mic

listened to sounds of the waveforms in (a) and (b) separately; the two sounds were different, the pitch of (b) gets higher than of (a). This perception was consistent with the statistics in Table 2.

Table 2 Peak-peak and RMS of phones of /voices/

	phones	peak-peak (mv)	RMS (mv)
input of cardioid Mic	/voi/	2661	515.8
	/c/	2628	316.4
	/e/	1845	367.8
	/s/	1641	190.5
output of cardioid Mic	/voi/	929.9	111.7
	/c/	5003	526.3
	/e/	764.8	77.4
	/s/	3159	331.8

Selected man's talking "speech" contains 3 phones s_pee_ch. Fig.9 (a) shows waveform of the front/rear Mic output. When the entire /speech/ enters the DM, it lasts 0.533s. We measured durations of /s/, /pee/ and /ch/, they last about 0.15, 0.2 and 0.18s, respectively. Fig.9 (b) shows the waveform of the DM output; comparing (a) to (b), we observe That level of each

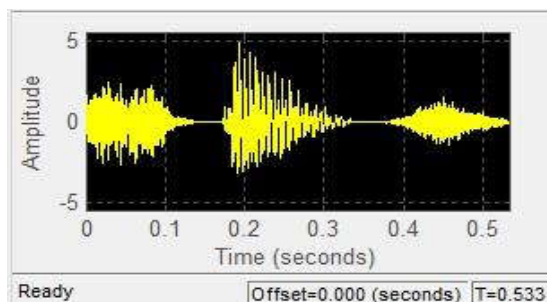

(a) Waveform of the front/rear Mic output "speech"

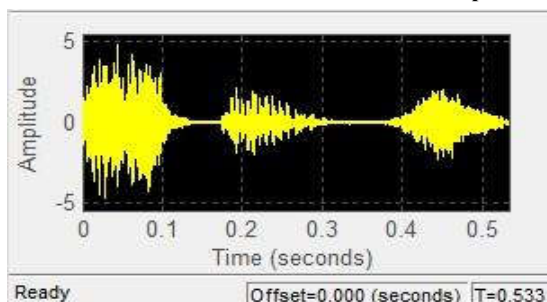

(b) Waveform of the cardioid Mic output "speech"

Fig. 9 Waveforms of man's talking "speech" at test points of cardioid Mic

phone changes significantly. Table 3 lists peak-peak and RMS values of the phones s_pee_ch; the /s/ and /ch/ are enhanced a lot but the /pee/ is declines a lot, as the changes in Fig.8.

Through the cardioid Mic, the voice waveforms change significantly, depending on the spectral components of each phone. When a phone contains more high frequencies, the DM gives it higher gain; vice versa. This behavior is consistent with the S-gain responses in Fig.7; in the region of most frequencies, when frequency of the tone is high, output of the DM is high; vice versa. By listening check, we also perceived that overall pitches of the "voices" and "speech" are getting high after cardioid Mic processing. We call this change of speech pitch the spectrum distortion of the DM, Obviously, the spectrum distortion cannot be ignored because it would affect the speech intelligibility.

Table 3 Peak-peak and RMS of phones of /speech/

	phones	peak-peak (mv)	RMS (mv)
input of cardioid Mic	/s/	5084	596.8
	/pee/	8069	995.6
	/ch/	3008	295.9
output of cardioid Mic	/s/	9481	1029
	/pee/	4175	374.7
	/ch/	4355	397.0

5. Conclusions

This article acquired extensive polar plots and waveforms of the cardioid Mic with pure tones, talking voices, babble noise and white noises by calculating, measuring and recording in our Simulink laboratory, and also acquired S-gain frequency responses of the DM by analysis programs. These obtained curves, data and waveforms are illustrative and reliable evidences to evaluate the behaviors of the cardioid Mic. We conclude that:

- In the pure tone field, the conventional cardioid Mic has excellent directivity, it cancels the undesired tones from the rear side very well. The DM enhances/declines the target tones of $>1.78\text{kHz}/<1.78\text{kHz}$, the max gain is 2(6dB); and it improves the S/N of the tones in noise well when the beamed noise intrudes from rear side only.
- In the talking voices field, the conventional cardioid Mic has excellent directivity, it cancels well the undesired voice or beamed noise from the rear side only, but the cardioid Mic cannot enhance the speeches, the gain of front voices is about 1(0dB) on average; thus, S/N improvement is inevitably conditional. Additionally, the cardioid Mic changes naturalness of the voices much; speech sounds of the DM output are perceived the pitch getting high, exactly speaking, it behaves with obvious spectrum distortion.

- In the babble noise field, the conventional cardioid Mic achieves the directivity. According to our test results from typical babble noise, the cardioid Mic still cancels the babble noise so long as the intruding noise beams from the rear side only; in listening environment, the intrusion of babble noise is always not rear beamed and the cancellation of the cardioid Mic is limited much, so the S/N improvement almost is impossible.
- In the white noise field, the polar pattern of the cardioid Mic is a circle curve with a zero notch at 180 °, its gain is constant, about 1.41 (3 dB); it can not cancel the white noise. However, some white noises in real-world are weakly correlated, e.g. a fan noise, the formed pattern is close to cardioid; but the cardioid Mic still cannot cancel the noise since the noise always is not beamed. It is impossible for the cardioid Mic to improve the S/N in speech plus white noise..

To summarise, the most effective situation for conventional cardioid Mic to improving S/N is that the noise is the undesired voice from rear side. It is weakly possible for the cardioid Mic to improve S/N in the realistic noise fields, such as babble or white noises. The major problem is that the cardioid Mic cannot enhance the target speech; and has to achieve the noise cancellation under harsh conditions, i.e. the high correlation of the undesired noise and the beamed intrusion from rear side only. Additionally, the voice spectrum distortion caused by the cardioid Mic is a crucial problem which cannot be ignored. By our researching, a DM architecture against these adverse behaviors should be combination of different DMs in a multi-channel processing.

References

- [1]. Keidser G, Rohrseitz K, Dillon H, et al. The effect of multi-channel wide dynamic range compression, noise reduction, and the directional microphone on horizontal localization performance in hearing aid wearers, *Int J Audiol.* 2006, 45:563-579.
- [2]. Chung K, Challenges and recent developments in hearing aids: Part I. Speech understanding in noise, microphone technologies and noise reduction algorithms, *Trends Amplif.* 2004, 8(3):83:124.
- [3]. Flynn MC., Maximizing the voice-to-noise ratio (VNR) via voice priority processing, *Hear Rev.* 2004 (2008, republished), 11:54-59.
- [4]. Chalupper J, Wu YH, Improving effectiveness of directional microphones with soft level directivity, *Hear J.* 2011, 64:44-49.
- [5]. Nyffeler M, Dechant S, Field study on user control of directional focus: benefits of hearing the facets of a full life, *Hear Rev.* 2009, 16:24-28.
- [6]. Gnewikow D, Ricketts T, Bratt GW, et al. Real- world benefit from directional microphone hearing aids, *J Rehabil Res Dev.* 2009, 46:603-618.
- [7]. Bentler RA, Effectiveness of directional microphones and noise reduction schemes in hearing aids: a systematic review of the evidence, *J. Am Audiol.* 2005, 16:473-484.
- [8]. Wu YH, Stangl E, Bentler RA, et al. The effect of hearing aid technologies on listening in an automobile, *J Am Acad Audiol.* 2013, 24:474-488.
- [9]. Phonak white paper, Binaural directionality, Stafa, Switzerland, 2010, 1-4.
- [10]. Mohon V, Analysis and synthesis of speech using MatLab, *International Journal of Advancements in Research & Technology*, 2013, 2:373-382.
- [11]. Voice Samples-LAMP Words for Life, <https://aacapps.com/lamp/voices>.
- [12]. Fontan L, Tardieu J, Gaillard P, et al. Relationship between speech intelligibility and speech comprehension in babble noise, *J Speech Lang Hear Res.* 2016, 58:977986.
- [13]. Mahendru HC, Khanna R, Spectral analysis of various noise signals affecting mobile speech communication, *International Journal of Scientific & Engineering Research*, 2014, 5:1087-1093.
- [14]. White Noise - MC2 Method, www.mc2method.org/white-noise
- [15]. White Noise CD, <http://www.lurklurk.org/whitenoise.html>.



Xubao Zhang received his doctorate in electronics from Xi'an Electronic Science and Technology University in China and was a postdoctoral fellow at McMaster University in Canada. He has been interested in hearing aid technology strategies and performance evaluation. He worked as Associate Professor at EE department of Xidian University and has worked as an EA and EMC engineer with Unitron Canada, and is the author of one book and more than 40 articles.

Appendix SimuLink laboratory procedures to study directional Mics

Study and verification of a cardioid Mic in pure tone fields can simply be conducted by means of derived formulas; but the obtained results cannot be exactly true to situations of voice and noise fields. A reliable and effective way is to use MatLab and realistic sounds to carry out. We established a SimuLink laboratory, which is based on MATLAB (ver. R2012a), Adobe Sound Booth (SB) CS4 (2009) and wave files of sounds recorded in real-world. Many powerful processing models and Time Scope, FFT Scope of SimuLink for electroacoustic experiments have been provided by Simulink; we developed many experiment programs which are used to emulate DM processors, to calculate, view, measure, listen to and record behaviors of the DMs with talking voices and various noises; and the obtained results are very close to those from the breadboard. Now, a part of the experimental procedures and results is described below.

A. Cardioid Mic configuration

Fig. A1 shows the experimental models of the cardioid Mic in our laboratory. We selected a Delay model as the internal delay filter and a Sum model as

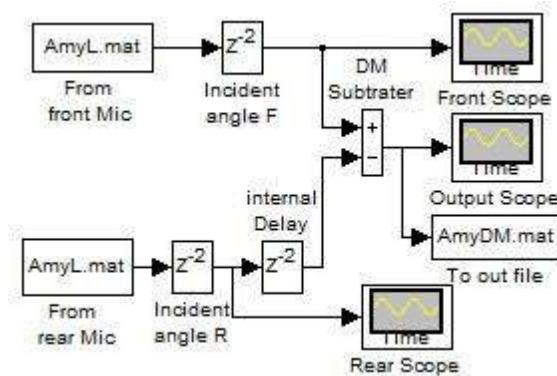

Fig. A1 Configuration of an experimental cardioid Mic and Time Scope models

the subtractor. Two Gain models with unit sensitivity are assigned as the front and rear Mics, and gains of two A/D converters are assumed 1; for simplicity, they all are ignored in Fig. A1.

The front Mic and the rear Mic outputs $y_f(t)$, $y_r(t)$ are recorded in one mat-file *AmyL.mat* without directivity, which results from woman's voice. When testing the DM with man's voice, babble noise or white noise, we need only to replace the file *AmyL.mat* with a corresponding mat-file, e.g. a man's voice file *BrianR.mat*. In Fig. A1, the digital signals are adapted, instead of the analogue signals in Fig.1, so the delay of the signal at rear Mic output cannot be controlled continuously. The incident angles are controlled discretely by two Delay models at the outputs of the front and rear Mics. We selected 2 of 5 time delays, z^{-2} , z^{-1} , z^0 in rear Mic output and z^{-2} , z^{-1} , z^0 in front Mic output to approximate one of incident angles at intervals of 45° , i.e. 0° , 45° , 90° , 135° and 180° . For smoother pattern curves, we interpolated 4 extra data at 22.5° , 67.5° , 112.5° and 157.5° between the obtained gain data, so totally 16 points (polar pattern is symmetric about 180°) were used. As for signal monitors, we used 3 of the same Time Scope models to view waveforms of the front Mic, the rear Mic and the DM outputs (selected as test points), respectively. These scopes also function as statistics analysers, so we can also view maximum, minimum and RMS, etc. of the waveforms. Fig. A1 is measuring behaviors of the cardioid Mic in the woman's voice "speech", and a mat-file *AmyDM.mat* at right is recording the output of the DM.

With reference to hearing aid product design, we selected the sampling rate 44.1kHz or 0.02268ms for the DM processor; many wave files in websites also use this rate. We selected 16mm ports spacing between the front and rear Mics, the spacing delay is $\text{spacing}/\text{velocity}=16\text{mm}/343.2\text{mps}=0.04662\text{ms}$; the delay filter τ (internal Delay) of the cardioid Mic is 0.04662ms too. filter.

B. Wave files recruiting

In our experiments, we needed several talking voices, babble noises and white noises from real-world. Some websites provide wave files which meet our requirements. A reference [11] provides many voice wave files of women's and men's talking; we took only two from their demonstrations: one contains a voice "speech" talked by Amy and another contains a voice "speech" talked by Brian.

Because of $0.04662\text{ms}/0.02268\text{ms}=2.06\approx 2$, we simply assigned a Delay model with delay unit 2 as the delay "voices" talked by Brian; /speech/ lasts 0.461s and is used for our illustrations in this article. Fig. B1 shows waveforms and statistics of the "speech"; the top panel is output of the front/rear Mic, and the bottom panel, output of the DM. Time series of the wave files are recordings of sampling rate 44.1kHz and word size 16bits, from stereo-channels.

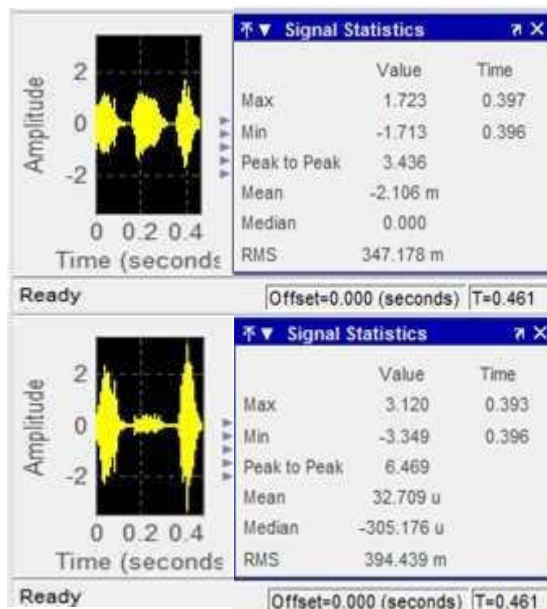

Fig. B1 Output waveforms of front/rear Mics and cardioid Mic with woman’s talking

Fortan, et al. [12] introduced their babble wave file, its sound was recorded in a 9-person party; when recording, the 9 persons all are continuously talking, and there is no outstanding voice from someone, so the time series is a typical babble noise. Before selecting it, we measured spectrum of the babble noise by FFT

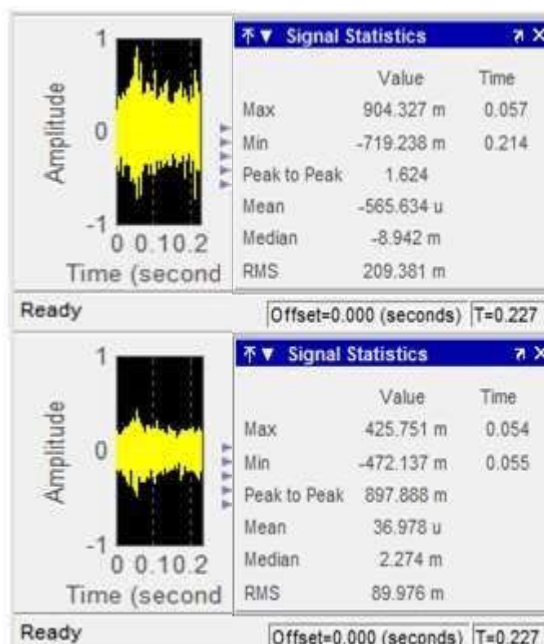

Fig. B2 Output waveforms of front/rear Mics and cardioid Mic with a babble noise

Scope, it has a 30dB higher spectrum of 0~1kHz than a flat spectrum of >3kHz; so it is a correlated noise. The babble series is acquired, of a duration 0.454s, we cut it into two segments of 10000 samples to view their difference. When one segment of the babble noise enters the cardioid Mic, the waveforms and statistics of the front/rear Mic output and the DM output are shown at the top and bottom panels of Fig. B2, respectively. The babble wave file was recorded at 44.1kHz and 16bits, from a mono-channel.

As for the white noise in our experiment, we selected a wave file from a reference [15], and tested it; it is uncorrelated, representing an ideal white noise. In Fig.6, the outer pattern of the cardioid Mic results from this white noise. We also selected another white noise [14], which is weakly correlated, representing a common white noise; we can also see its behavior, i.e. the inner pattern in Fig.6. The time series of recruited white noises have the same sampling rate 44.1kHz and word size 16bits, from a mono-channel. All the wave files must be listened to by the Adobe SB and tested by FFT scope to verify that they meet our requirements before recruiting them as test sound sources.

C. Wave files operating

After recruited the wave files of the voices, babble noise and white noises, we can read out their time series and save them into mat-files; so the modelling cardioid Mic can invoke them for processing later. We operated these wave files by

running some instructions in Workspace (syntaxes in MatLab) and by programming m-files in MatLab. Now, we read out time series and parameters in a wave file by the syntax: `[Din, Fs, Nb]=wavread ("Amy0_5s.wav");`, where *Amy0_5s.wav* is the read wave file; *Din* is data vector, to which the time series will be saved; *Fs* and *Nb* are recording parameters, sampling frequency and word size, respectively. We can listen to sound of the vector by the syntax: `soundsc(Din, Fs);`; this sound is to be perceived the same as we listen to *Amy0_5s.wav* by the Adobe SB; then we can save the data vector and the *Fs* into a matfile in Workspace, e.g. *AmyL.mat*. Later we can invoke the mat-file as the voice source at any time for DM processing as in Fig. A1. After the cardioid Mic processing, we also save the output of the DM into another mat-file, e.g. *AmyDM.mat* in the Fig. A1, and assign a data vector *Dout* into this mat-file; then use the syntax: `soundsc(Dout, Fs);` for listening check, or send *Dout* into Time Scope for viewing waveform. We also can write the data vector *Dout* into a new wave file by the syntax: `wavwrite(Dout, Fs, "AmyDM.wav");`; then the wave file *AmyDM.wav* can be opened by Adobe SB to test or sent to colleagues for further verification.