

STEP-ACTIVATED POWER GENERATION SYSTEM

Prathyush Korisaliyil Bijukumar^{1*}, Abhinav Singh Rawat², Ravi Kumar S³, Surya Balan S⁴,
Arun Manickam R⁵

^{1*}*Mechatronics Engineering, Acharya Institute of Technology, prathyushd.22.bemt@acharya.ac.in*

²*Mechatronics Engineering, Acharya Institute of Technology, abhinavd.22.bemt@acharya.ac.in*

³*HOD of Mechatronics, Acharya Polytechnic, ravikumar@acharya.ac.in*

⁴*Mechatronics Engineering, Acharya Institute of Technology, Suryas.22.bemt@acharya.ac.in*

⁵*Mechatronics Engineering, Acharya Institute of Technology, arunr.22.bemt@acharya.ac.in*

*Corresponding Author

*Email id: prathyushd.22.bemt@acharya.ac.in

Abstract—

As the economy of the world grows, the demand for energy increases as well. The energy sources that would be able to satisfy this demand need to be sustainable and non-conventional in nature. The current innovation illustrates a method for harvesting electrical energy from human locomotion using a human powered generator utilizing a rack and pinion mechanism and spur gears. The provided mechanical energy is converted to electrical energy without the consumption of fuel, thus solving one more environmental challenge. The gear arrangement of the device comprises of racks and pinion, gear drives, alternator, and a battery to store energy. The electricity produced from footsteps can power streetlights, public buildings, and intelligent pedestrian paths. While this technology requires an investment at the beginning, its long-term profitability makes it appealing. This report elaborated on its working principles, how effective it is, what else can be done with it, and why this innovation should be funded as an alternative energy source.

"Step into the future—where every footstep powers a sustainable world."

Keywords— *Step-Activated Power Generation System, Renewable Energy, Rack and Pinion Mechanism, Spur Gear System, Kinetic Energy Harvesting, Human Motion Energy, Sustainable Power, Non-Conventional Energy, Smart Walkways, Energy Harvesting Systems.*

I. INTRODUCTION

In the backdrop of a worldwide energy crisis and diminishing reserves of conventional fossil fuels, a rapid transition to sustainable alternatives becomes imperative. Conventional renewable sources like the sun and wind face their own intrinsic challenges of intermittent. Nonetheless, kinetic energy can provide one of the most feasible solutions to this problem that has generally been underutilized. This project presents a footstep energy harvesting system that works through rack-and-pinion and spur gear transmission techniques for converting mechanical motion into electrical energy. Load-responsive tiles move vertically in response to pedestrian activities, thus energizing a gear-train-driven micro generator to produce energy. This type of flooring is self-sustaining from the energy view: cost-efficient, environmental-friendly, and functioning completely independent of any external sources. It is designed to be used in very high foot traffic areas like cities and transport centers and to provide a decentralized power supply with minimal investment. The prototype is made to work to 2-3 volts to demonstrate utility energy conversion by LED illumination. First, a direct racket drive is employed, and then an optimized gear assembly is put in place to enhance energy output. Then, a power storage module with an inverter circuit makes it possible to convert DC to AC for practical use via a power converter. This global kinetic energy transduction by this system adds to a scalable and innovative power model consistent with global renewable energy goals. [1],[2],[5],[6],[14]

II. CHALLENGES

In fact, a lot of challenges await the Step-Activated Power Generation System to become efficient and scalable. Large-scale implementation of the energy floor system is hampered by high upfront costs and the need for specialized components, including sensors, which are currently not mass-produced, and power electronics. Even if those problems, particularly the power output problem, were solved, there remains the issue of basic structural integration. It has to be attached to a building so that besides giving strength, it is pleasing and ergonomic in appearance. Biological exposure is another aspect. The energy floor system must also bear up to exposure to moisture, dust, and other biological environmental life forms without jeopardizing its long-term reliability. Solving these problems through intelligent energy management and system optimization, and addressing some of the manufacture issues through materials innovation, would likely be the pathway to achieving the energy floor system's commercial viability and sustainable long-term deployment in the spaces it was designed to serve.[3],[9],[12],[13],[17] surfaces and controlled displacement limits to ensure pedestrian comfort without compromise. These quality metrics determine the feasibility and scalability of step switching systems in real-world applications.[11],[15],[16],[19]

III. TECHNICAL ADVANCEMENTS

Advances, in capturing energy from footsteps have boosted effectiveness and longevity by enhancing components such as springs with improved rigidity for optimal force propagation to maximize mechanical energy transfer, in the rack and pinions segment together with precision crafted spur gears now featuring reduced friction coatings and composite materials to cut down on mechanical losses and enhance endurance. [4]

DC generators designed for efficiency and optimized for RPM contribute to improved energy conversion by reducing resistance levels effectively. The use of shaft materials made from high strength alloys enhances both stability and mechanical reliability. Additionally, inverter circuits based on PWM technology play a role in facilitating efficient conversion from DC to AC power thereby stabilizing voltage levels for various practical uses.[7]

The field of energy storage has progressed significantly with the development of high-capacity lithium-ion batteries and supercapacitors which have improved the ability to retain and discharge charges efficiently. Furthermore, smart LED units incorporating energy yet luminous diodes not only boost energy efficiency but also serve as effective system indicators. Moreover, monitoring systems equipped with technology allow for real time performance assessment facilitating energy management. These developments mean that generating power, from footsteps, is now a feasible renewable energy option for places with high pedestrian traffic.[8],[10],[18]

IV. QUALITY METRICS

The most important quality metrics for mechanical, electrical and structural components ensure reliability and efficiency of energy use systems. A comprehensive evaluation is required. Energy Efficiency is an important parameter measured by electrical conversion rates that rely on optimized rack and pinion mechanisms, spars wheels, and highly efficient DC generators. Minimizing friction losses and improving rotational energy transfer directly improves performance. Durability and load capacity requires materials that play a critical role in long-term performance and have wear resistance and mechanical strength. Components such as springs, waves, gears, etc... must undergo stress analysis to withstand continuous pedestrian traffic. To ensure initial stability, DC voltage fluctuations using PWM-based inverter circuits are regulated, and the battery and supercapacitors are tested in terms of load, discharge efficiency and lifespan. The structural integrity of the system must meet the standard of load burden to prevent deformation over time, particularly in high-foot environments. Additionally, environmental compensation is important as exposure to moisture, dust and temperature fluctuations can affect system performance. Finally, user security and ergonomics require non-slip.

V. METHODOLOGY

A. Introduction:

The footstep stream generation system follows a structured process and provides efficient energy from mechanical motion in electrical performance. Ensure conversion. The system operates with the help step to drive the rack and pinion mechanism, converting vertical shifts into rotary movements. Spurs rank further strengthens this movement and sends it to the dc generator via the shaft. This generates electrical energy.[6],[7]

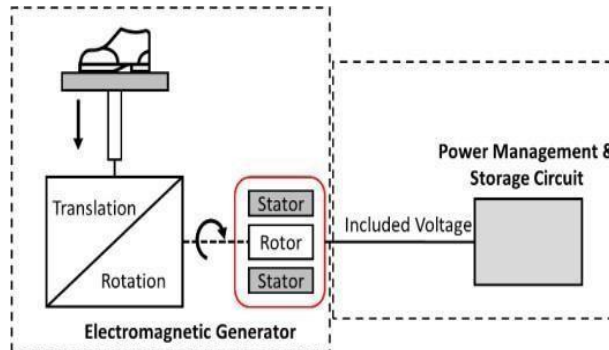

Fig.1 - Methodology of circuit

B. Circuiting:

The voltage stabilizer circuit is used to regulate the generated dc performance and store it for later utilization with the battery. A PWM based inverter circuit is incorporated to convert DC to AC for the purpose of using it with conventional electrical loads. Equipped with LED indicators to prove the power generation conditions, the system's sides have undergone rigorous testing evaluations, such as efficiency, mechanical robustness, voltage regulation and environmental period. The key features are analyzed to allow the system to support the continuous presence of pedestrians to stop structural damage. These components are even more refined, optimized for energy transmission, and this methodology creates a scalable and sustainable footprint. [3],[7],[10],[12],[15],[18],[20]

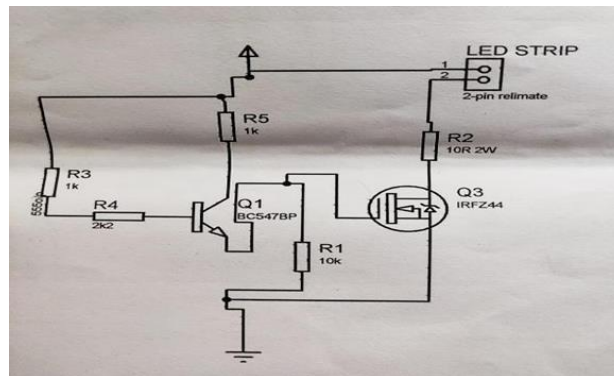

Fig.2- Circuit 1

An LED strip driver using an MOSFET (IRFZ44) and a BJT transistor (BC547bp), which is responsible for power control, is the first element in the circuit. A switch, which is active when BC547bp transistor switches on, flows through a MOSFET that controls the power flowing to an LED strip. The power at the input is R1, R3, R4, R5, and the reactive power unit R2 (10, 2W) which limits the power is electric energy restrainer. This method, which is used to control lights at high power output through automatic control systems and low power supply signals, is very suitable for very energetic applications.

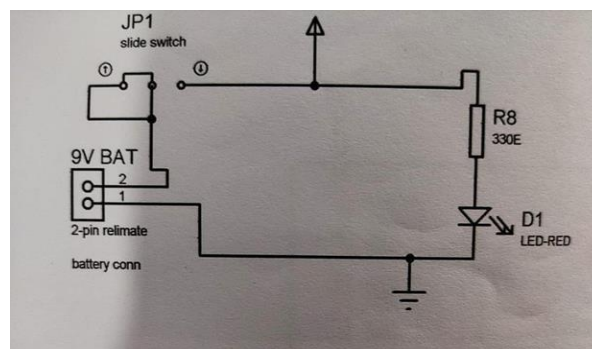

Fig.3- Circuit 2

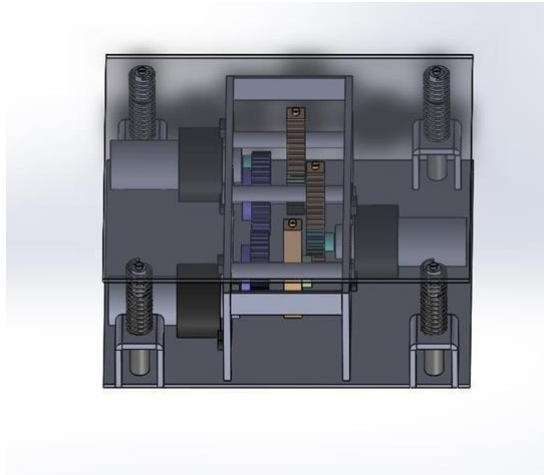

Fig.7- Top View

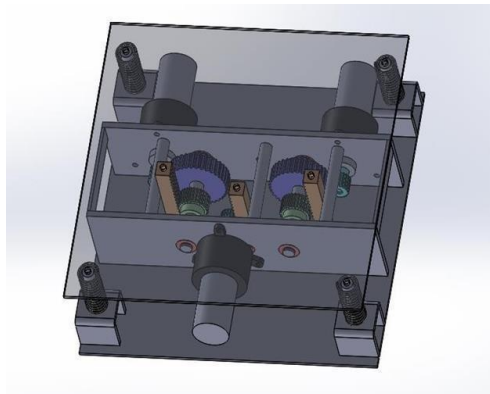

Fig.8- Side view

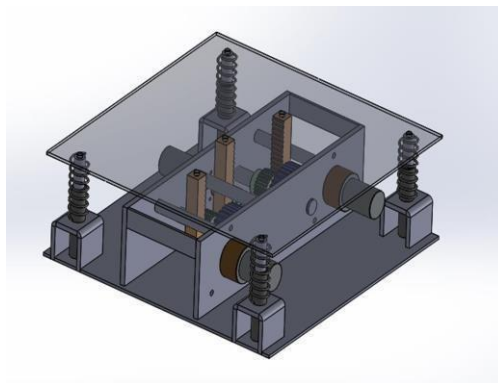

Fig.9- Perspective View

VI. MECHANISM

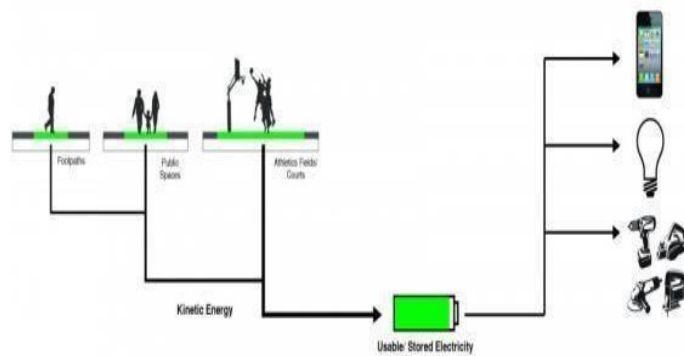

Fig.10- Working Flow

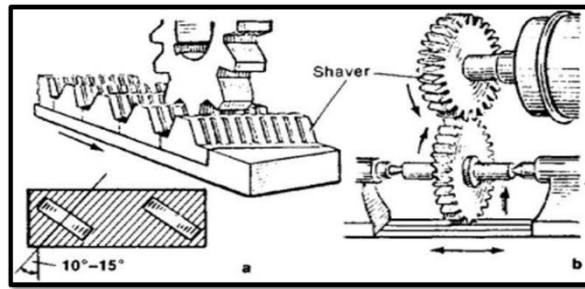

Fig.11- Mechanism

A. Introduction:

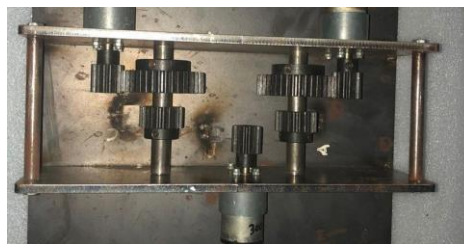

Fig.12- Gears placement

The Step-Activated Power Generation System mechanism converts mechanical energy, derived from footsteps, into electrical energy. It does this through a rack and pinion mechanism that converts linear motion into rotational motion thus driving a DC generator. This electricity is stored in a battery, from which light or small devices can be powered through an inverter. This system in particular subtlety works in high foot-traffic areas like malls and railway stations giving more emphasis for sustainable energy. It captures human energy that would otherwise be wasted and is ideal for public spaces in smart cities because it has low maintenance requirements and is highly efficient renewable energy power.

B. Working Principle (Rack & Pinion mechanism):

The working principle of the apparatus in question consists of a rack with a pinion system conversion of the upward motion of the platform into rotational energy. Once a person stands on the platform, the rotation of the springs helps in downward movement of the plate, such that the rack engages itself with the pinion. The pinion is connected to a gear train that transfers the rotational motion, thus increasing speed and improving energy transfer. The rotation sets a DC generator into action, converting mechanical motion into electrical energy. The electrical energy generated may either be stored in the battery or supplied to devices like LED lights or charging stations. Once the foot is lifted, the springs return the platform to its original position, resetting the system for the next step. Such continuous up-and-down motion helps harvesting processes very efficiently without requiring input



Fig.13- Rack & Pinion arrangement

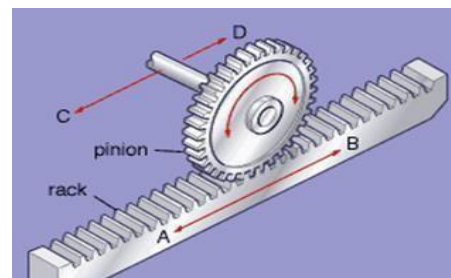

Fig.14- Rack & Pinion Mechanism

VII. BLOCK DIAGRAM

Block Diagram Explanation:

Below is the breakdown for the construction of a diagram that illustrates the working of a Step-Activated Power Generation System mechanism that changes physical energy from walking into electrical energy. In addition, here is how the system works in further detail:

i) Footstep Arrangement:

At the system, when a person steps, a mechanical force is exerted on a moving plate.

ii) Rack and Pinion and the Gear Arrangement:

With the system, the energy coming from the footsteps is turned into rotational movement by using a rack and pinion mechanism.

iii) Gear System:

A gear system is used to increase the speed of rotation of the components within the system, so that energy can be transformed more efficiently.

iv) DC Generator:

At the output of the DC generator is the point at which rotational energy is turned into electrical energy. Battery: The electrical energy is stored for use by a battery.

v) Inverter:

Generally, since most devices need alternating current, the stored direct current shall be converted into alternating current by means of an inverter.

vi) Light:

The final output thus obtained is used for lighting or other electrical devices.

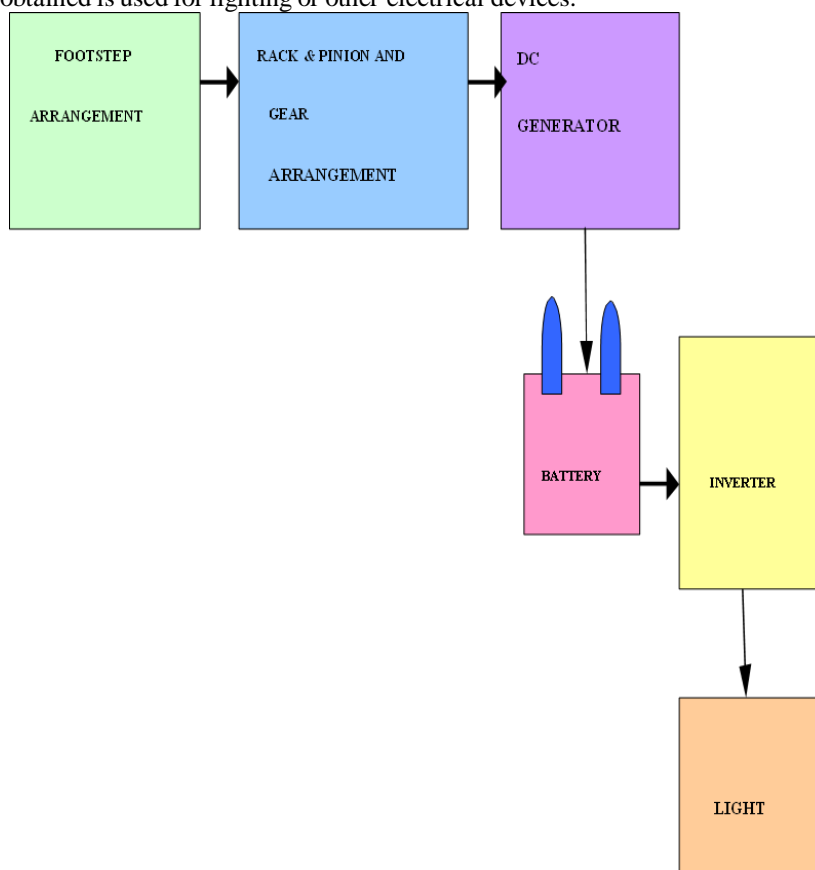

Fig.15- Block diagram

VIII. HARDWARE SPECIFICATIONS

The requirements regarding the hardware of the footstep energy harvesting system includes rack and pinion mechanism, which changes rotational motion to linear motion, gear system, which increases the rate of rotation, and DC generator, which transforms mechanical energy to electrical energy. In addition, the system needs a battery to store energy, an inverter for the DC to AC conversion, and a light as the load to use the produced power. The components must be strong enough to support a lot of foot pressure use and ensure maximum energy output and reliability for a long period of time, which changes energy into and provides the utmost functionality.[2],[4],[6],[9],[14],[16],[19].

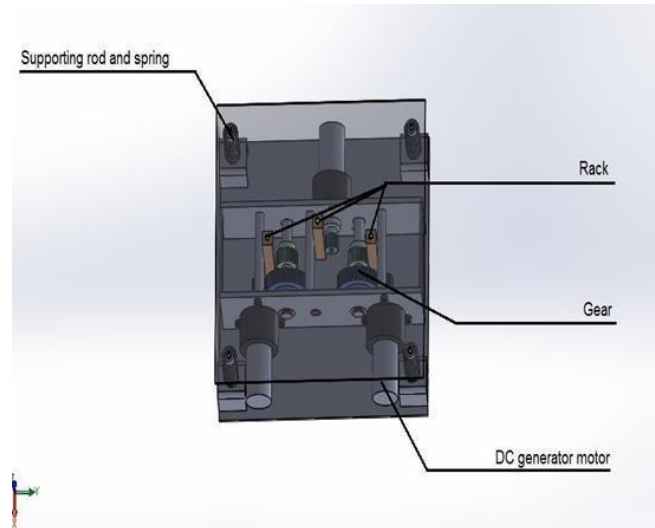

Fig.16- Hardware placement

A. Capacitors:

Capacitors accumulate and release electricity, stabilizing voltages and filtering noise. C1 (104 μ F) is expected to serve the functions of timing or filtering in the circuit, while C5 (10 μ F) could be employed in power supply stabilization or transient suppression. The frequency of oscillation in 555 timer circuits depends on the capacitance values, while motor circuits use them to reduce electrical noise. The values indicated are a measure of their ability to store a charge determining circuit operation by enabling or disabling timing functions and reducing voltage ripple.



Fig.17-Capacitor (104 μ F)



Fig.18- Capacitor (10 μ F)

B. Resistors:

Resistors allow the current or voltage distribution. R1, R7 (10K Ω), shall limit the base current for the transistor circuits. R2 (10 Ω , 2W) is for handling where power dissipation is expected to be high. R3, R5, R6 (1K Ω) find usage in signal conditioning or limiting the LED current. R4 (2K Ω) might be influencing timing in the 555 integrated circuit. R8 (330 Ω) is most probable a current-limiting resistor for an LED. R9 (100K Ω) could be considered a pull-down resistor, which would ensure the stability of the logic state in switching circuits.



Fig.19- 10K Ω Resistor



Fig.20- 1K Ω Resistor



Fig.21- 10Ω Resistor

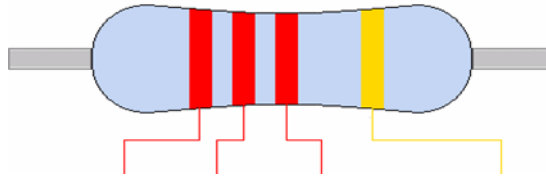

Fig.22- 2KΩ Resistor



Fig.23- 330Ω Resistor

C. Integrated Circuits:

The 555 timer (U1) is a highly stable integrated circuit and is used for the purpose of producing precise time delays and oscillations. Depending on the circuit configuration, it can work in stable, monostable, or bistable modes. It most likely acts as a pulse generator in this circuit, controlling the operation of a motor or the flashing of an LED. External capacitor and resistor networks determine its timing characteristics.

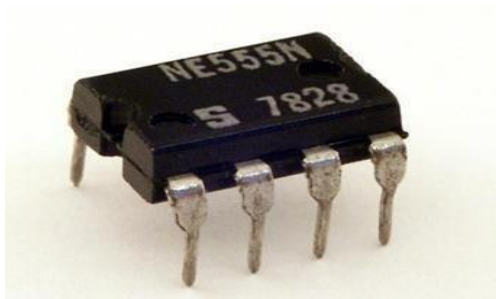

Fig24.- 555 IC

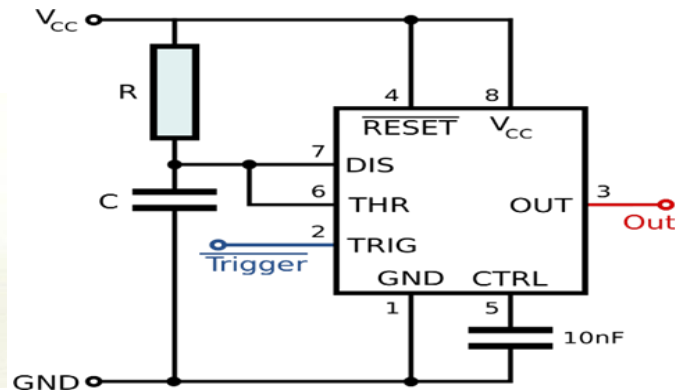

Fig.25- 555 IC Timer layout

E. Diodes:

The LED-RED (D1) serves as indicator lights for circuit operation, indicating power status or signal activity. The diode 1N4007 (D3) serves as a general-purpose rectifier diode, protecting circuits from current in reverse and back- emf induced from a motor that puts circuit components at risk of damage.

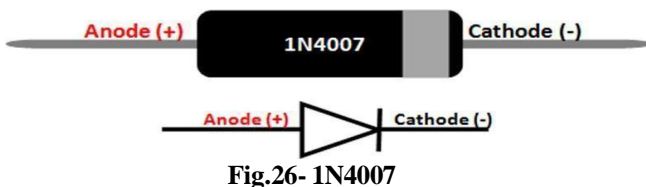

Fig.26- 1N4007



Fig.27- LED.

D. Transistors:

BC547BP (Q1, Q2) are NPN bipolar junction transistors used for switching and amplification of signals. They serve as low- power electronic switches or amplifiers used for motor driver circuits. IRFZ44 (Q3) is an N-channel MOSFET, and it is capable of passing high current loads efficiently. It should work as a switching element for the motors and indicate whether the power control comes from the timer IC.

BC547 Transistor Pinout

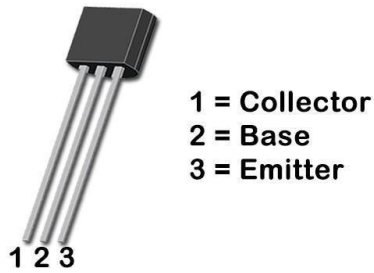

Fig.28-BC547

IRFZ44 Pinout

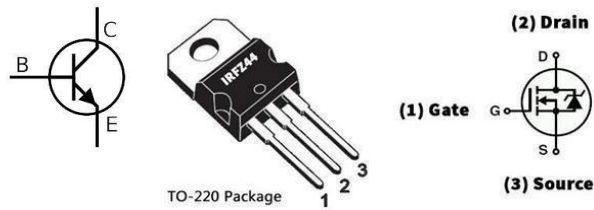

Fig.29-IRFZ44

F. DC Motors:

Three 300 RPM 12V DC motors (J1, J2, J3) convert electrical energy into mechanical motion. They are probably powered through the MOSFET and transistor circuit, so there is enough controlled operation. Depending on application, these motors may be used for automation, movement, or mechanical actuation.



Fig.30- Dc Motor.

G. Connectors:

A B2 pin power connector, J4, is available for power input or motor connections to ensure current flow and voltage distribution across the circuit.



Fig.31- PBT Connector.

H. Miscellaneous Components:

The 9V batteries deliver power to the circuit, maintaining an operation mode for 555 timers, transistors, and motors. The LED strip contained provides visual proof, possibly powered by the circuit itself. The 2-pin relimate connector makes secure wiring connections very convenient. JP1, the slide switch, can control the power to the circuit manually, switching on or off power or mode of operation.



Fig.32- 9V battery.

IX. PROJECT OVERVIEW



Fig.33- Right View



Fig.34- Left View



Fig.35- Back View



Fig.36- Top View

X. OUTCOME

The functioning of the proposed energy harvesting scheme has been achieved, demonstrating its practical feasibility. This mechanism effectively converts mechanical energy from human footsteps into electrical energy via a rack and
Volume-11 | Issue-01 | Mar 2025

pinion coupled with a DC generator. Electrical energy from the battery is later used via an inverter for powering electrical loads, i.e., LED illumination. User-friendly and flexible operations and automation are guaranteed by integrating electronic components like timer 555, MOSFET switch, and relay. The results have validated the capability of the system promoting a potential to yield renewable energy in target areas with high foot traffic; hence it is a very promising solution for sustainable energy application.

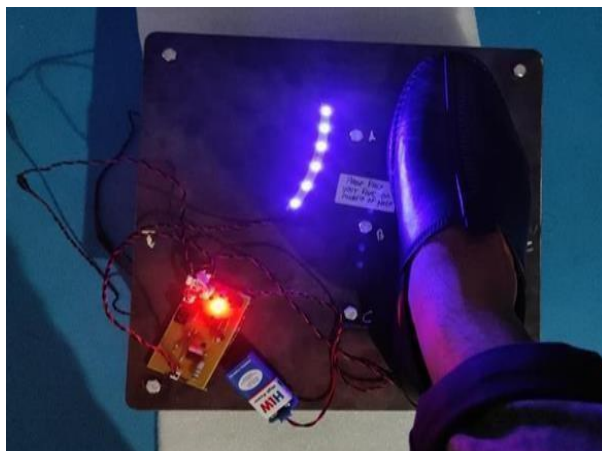

Fig.37-Result

XI. CONCLUSION

The objective of the project is to verify the feasibility of producing electricity from human footsteps through a rack and pinion system linked to an electric DC generator. In real life, this shows the very real potential of light that is harnessed through the battery to generate power. Capacitors, resistors, transistors based on an older 555-timer circuit, and the latter ensure that the energy being taken is converted and controlled by the appropriate electronic components. The system offers a sustainable, low-maintenance, and environmentally friendly approach to energy generation in large quantities. This is advantageous.

XII. REFERENCES

- [1]. R. K. Akki and S. K. Oza, "Generation of electricity through footstep power," *International Journal of Engineering Research and Applications*, vol. 4, no. 3, pp. 209–214, 2014.
- [2]. S. R. Patil, P. R. Chaudhari, and S. S. Chaudhari, "A review on electricity generation from footsteps," *International Journal of Scientific & Engineering Research*, vol. 6, no. 4, pp. 1234–1239, 2015.
- [3]. S. Kumar, V. Gupta, and R. K. Saxena, "Electricity generation through human footsteps using piezoelectric sensors," *International Journal of Scientific Research in Science and Technology*, vol. 8, no. 2, pp. 15–20, 2019.
- [4]. M. N. Azim, S. K. Paul, and A. R. Chowdhury, "Footstep power generation using rack and pinion mechanism," *Proceedings of the International Conference on Electrical Engineering and Information & Communication Technology*, Dhaka, Bangladesh, pp. 1–6, 2016.
- [5]. S. P. Bhosale, S. S. Pujari, and P. P. Patil, "Design and analysis of footstep power generation system," *International Journal of Engineering and Advanced Technology*, vol. 7, no. 6, pp. 123–128, 2018.
- [6]. T. S. Kumar and V. R. Prabhu, "Power generation using footstep energy," *International Journal of Advanced Research in Electrical, Electronics and Instrumentation Engineering*, vol. 4, no. 7, pp. 5672–5677, 2015.
- [7]. R. Mehta, R. Chauhan, and S. Yadav, "Design and implementation of footstep power generation system using rack and pinion mechanism," *International Journal of Emerging Technologies in Computational and Applied Sciences*, vol. 6, no. 3, pp. 147–152, 2018.
- [8]. S. A. S. Junaid, A. Hussain, and M. A. Khan, "A novel approach to footstep power generation system using rack and pinion," *International Journal of Mechanical Engineering and Robotics Research*, vol. 9, no. 2, pp. 27–32, 2020.
- [9]. N. K. Agarwal and R. Verma, "Footstep energy generation using mechanical motion rectifier," *International Journal of Scientific and Engineering Research*, vol. 10, no. 5, pp. 45–51, 2019.
- [10]. J. D. L. Gunasekara, "Kinetic energy harvesting from human motion: A review," *Renewable and Sustainable Energy Reviews*, vol. 96, pp. 1–20, 2018.
- [11]. H. S. Narkhede and M. G. Wagh, "Renewable energy source: Electricity generation through footsteps," *International Journal of Advances in Engineering Research*, vol. 12, no. 5, pp. 245–251, 2020.
- [12]. S. U. Nimbalkar, M. P. Bhagat, and P. S. Shinde, "Analysis of footstep energy harvesting system using piezoelectric sensors," *International Journal of Emerging Technologies and Innovative Research*, vol. 7, no. 3, pp. 212–219, 2019.
- [13]. R. Rajkumar and A. K. Singh, "A study on footstep energy harvesting using mechanical and piezoelectric methods," *International Journal of Mechanical Engineering and Technology*, vol. 9, no. 4, pp. 354–361, 2018.
- [14]. Y. M. Jadhav and S. G. Jagtap, "Electricity generation through footstep mechanism: A review," *International Journal of Advanced Research in Electrical, Electronics and Instrumentation Engineering*, vol. 7, no. 1, pp. 567–572, 2017.

- [15]. A. D. Bhosale and M. R. Mane, "Power generation using footsteps in crowded areas," *International Journal of Electrical and Electronics Research*, vol. 8, no. 2, pp. 112–118, 2021.
- [16]. R. K. Patel, P. Gupta, and S. Sharma, "Performance evaluation of a footstep power generation system with rack and pinion arrangement," *Journal of Energy Research and Environmental Technology*, vol. 6, no. 2, pp. 78–85, 2021.
- [17]. M. S. Khan and A. P. Singh, "Implementation of renewable energy sources in smart cities: Footstep energy harvesting," *International Journal of Scientific Research in Science and Technology*, vol. 10, no. 5, pp. 30–39, 2022.
- [18]. A. R. Dhote and A. S. Ingole, "Electricity generation from footsteps: An energy harvesting approach," *Renewable Energy and Sustainable Development*, vol. 5, no. 1, pp. 77–84, 2020.
- [19]. P. K. Mehta, R. G. Joshi, and S. H. Mishra, "Mechanical energy harvesting using footstep pressure in public places," *International Journal of Energy and Power Engineering*, vol. 13, no. 3, pp. 65–71, 2019.
- [20]. B. K. Reddy, S. M. Jadhav, and R. V. Patil, "Utilization of mechanical energy from footstep pressure for electricity generation," *Journal of Sustainable Energy Technologies and Assessments*, vol. 14, pp. 21–29, 2018.