

SPIDER HEXAPOD ROBOT BASED ON STM32F429

Wang Weiqi^{1*}, Wang Aogang², Dong Huaxiong³, Zhu Yuxin⁴, Zhou Yun⁵

^{*1,2,3,4,5}School of electronic information, Jiangsu University of Science and Technology.

***Corresponding Author:-**

Abstract:-

A multi-legged intelligent walking robot was developed for the purpose of industrial inspection in this paper. The robot described in this article is STM32F429 as the main control chip, equipped with ultrasonic module for automatic obstacle avoidance, gyro module for direction designation, voice module for command control, temperature and humidity, camera sensor for data collection, through the serial port to the rudder with atmega328 chip The machine control board sends the serial port commands to form a closed-loop automatic control to realize the integrated control of 18 servos, and achieve the purpose of automatically inspecting and collecting environmental data in real time in the factory.

Keywords: - hexapod robot STM32F429 closed-loop automatic control factory inspection

1 INTRODUCTION

At present, robots can be divided into wheeled robots, crawler robots, and foot robots according to the way they walk. Among them, wheeled robots have the advantages of high speed, easy control, and good stability. However, they require high road conditions. For example, they require the ground to be relatively flat and continuous, and the environmental adaptability is poor, and the ability to avoid obstacles is also not good. Tracked robots have good stability and strong field operations, but they are relatively large and have certain requirements for road conditions [1].

The foot robot has good maneuverability and can use discontinuous ground support. When there is limited foothold, some discrete points can be selected as footing points, and the position of the body posture and center of gravity can be adjusted by adjusting the extension of the legs. It is not easy to overturn and has good stability. Therefore, foot robots do not require high road conditions and may be discontinuous terrain. Therefore, the foot-type robot can adapt to various unstructured grounds and harsh environments, and can achieve various gait, flexible obstacles and other advantages [1]. For the actual plant environment, we envisage using a six-legged walking robot equipped with a feedback control sensor to implement an automatic closed-loop control of the hexapod robot and a data acquisition sensor to monitor the factory environment.

2 Implementation plan

2.1 Mechanical mechanism and gait design

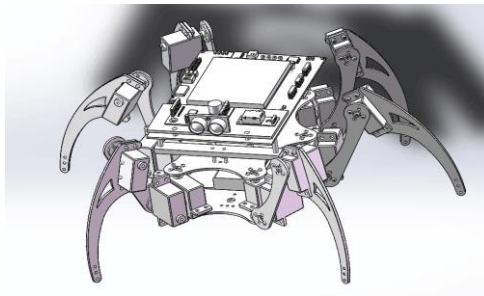

Figure 1 SolidWorks Simulation

When walking on the hexapod (insects, ants, etc.), the hexapods generally do not go straight at the same time. Instead, they divide the three pairs of feet into groups and alternately move forward with the triangle bracket structure. The front and rear feet of the left side of the body and the right side of the middle foot are a group. The right front and rear feet and the left side of the middle foot are the other groups, which form two triangular stents. When all the feet in one group of triangle brackets are lifted at the same time, the three groups of the other triangle brackets remain in place, supporting the body and using the middle group as the fulcrum. The muscles of the front and rear tarsal muscles contract, pulling the body forward and hindfoot. The muscles of the ganglion contract and push the worm body forward, so the body slightly rotates with the midfoot as the fulcrum. At the same time, the center of gravity of the worm body falls on the three legs of another group of "triangular stents", and then the former group is repeated. The actions are exchanged with each other and repeated. This way of walking allows insects to stop at any time and place, because the center of gravity always falls within the triangle bracket.

This is the typical triangular gait walking method. Triangular gait is a waveform gait with $\beta = 1/2$. When moving, six legs are alternately supported by two sets of triangles to move forward. Its walking trajectory is not a straight line, but is in the form of "zigzag" [2].

2.2 Motion Control System

2.2.1 Voice Control

Speech Recognition Technology (ASR) is a high technology where the machine transforms speech signals into corresponding text files or commands by identifying and understanding the process. Speech recognition is essentially a pattern matching recognition process. The speech recognition process basically includes four parts: speech signal pre-processing, speech feature extraction, training and recognition [3]. Through the serial communication (communication baud rate 115200) way to use YS-LDV7 voice recognition module to achieve multiple action group voice control, including action switching, etc.; voice recognition link is divided into first and second order instructions, a The instruction is "please prepare", and the second instruction includes "forward", "back", "turn left", "turn right", "stop", etc. Only when the level 1 instruction is successfully recognized, the level 2 instruction can be received and successfully identified once, and thus more stringent implementation of "one to one" instruction recognition system.

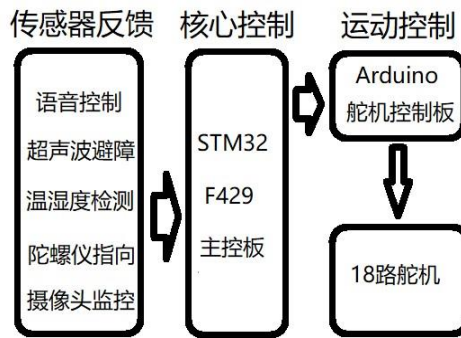

Figure 2 internal control flow chart

2.2.2 Ultrasonic control

The STM32F429 control board is equipped with an external ultrasonic sensor and servo (used to indicate the direction of the spider's head), so that the left, right, front, and back directions of the ultrasonic wave can be sampled, quantized, and coded through the AD conversion link, and finally displayed on the capacitive screen. Through the user-defined safety range for spiders to use the steering head steering instructions and serial communication to achieve the corresponding action group switch, so as to achieve the spider through intelligent detection and analysis of the automatic control walking links.

2.2.3 Gyro Pointing

The MPU6050 six-axis sensor chip integrates a 3-axis MEMS gyroscope and a 3-axis MEMS accelerometer. Each axis has a 16-bit AD converter with a measurement range of $\pm 16g$, and its high resolution (3.9mg/LSB) can be measured. 1° tilt angle changes. When the chip works normally, the gyroscope and the accelerometer collect the voltage values of the x-axis, y-axis, and z-axis, respectively, and then convert them into digital signals through AD conversion. Finally, they are transmitted to the control chip through the I2C bus, but the value obtained at this time is not changed. Instead of the actual angle and angular velocity values, they must also be converted after a certain proportional relationship to obtain the actual angle and angular velocity values [4].

2.2.4 Remote control with smart handle

By installing the PS handle receiver to the servo control, the smart wireless control link for performing and switching the multiple action groups of the spider is realized by controlling two sets of joysticks of the PS handle.

2.3 Data Acquisition System

2.3.1 Temperature and Humidity Collection

The internal structure of the DHT11 digital temperature and humidity sensor includes a resistive moisture sensing element and an NTC temperature measuring element and is connected to a high performance microcontroller. Therefore, the sensor has the advantages of fast response, strong anti-interference ability and high cost performance. Each DHT11 sensor is calibrated in an extremely accurate humidity calibration chamber. The calibration coefficients are stored in the OTP memory in the form of a program. These calibration coefficients are to be called within the sensor during the processing of the detection signal [5].

By installing an external temperature and humidity sensor to the STM32F429 control board, the temperature, humidity and humidity can be sampled, quantified, and coded through the AD conversion link, and finally displayed through the capacitive screen; and the program is provided with upper and lower limits of temperature and humidity, through the software part of the cyclic scan. The comparison function thus realizes the automatic alarm link of temperature and humidity detection and the indication of the LED lamp.

2.3.2 Image Acquisition

The image sensor is a CMOS type digital image sensor model OV5640. The sensor supports output of up to 5 million pixel images (2592x1944 resolution), supports output of image data using VGA timing, and the output image data format supports YUV (422/420). STM32F4 series controller includes DCMI digital camera interface (Digital camera Interface), which supports the use of VGA timing to obtain image data stream.

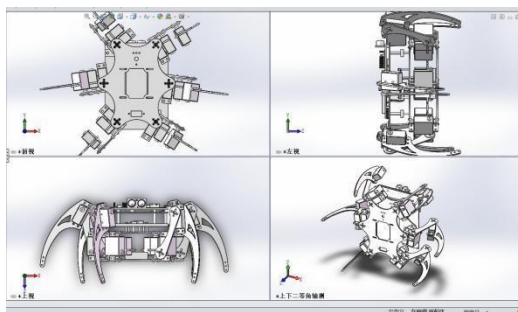

Figure 4 SolidWorks simulation

3 Actual works

This paper elaborates on the implementation of the STM32F429 based spider six-legged robot, and adds a lot of functions to the industrial inspection scene.

In the actual work, first of all, the 18-way steering gear movement system based on the servo control board is debugged to ensure the normal movement of the robot. Then the sensor part is debugged and combined to ensure the correct validity of the sensor feedback data. Finally, the overall integration, so that the feedback system and the motion system form a complete and effective closed-loop chain. And in this process, using SolidWorks software for simulation, it is easy for us to further optimize the robot.

Finally completed one of the following works.

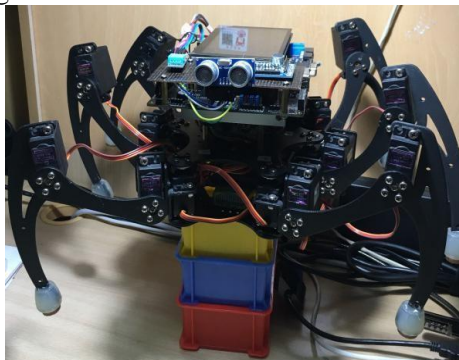

Figure 5 works picture

References

- [1].Li Zhe. Gait planning and adaptive control of multi-legged robots[D]. Northeastern University, 2011.
- [2].Qi Xiangjun, Chen Lin, Liu Mingdan. Research on the Triangular Gait Control of Six-legged Bionic Robot[J]. Computer Simulation, 2007(04):158-161.
- [3].Liu Ronghui, Peng Shiguo, Liu Guoying. Embedded Speech Recognition System Based on Smart Home Control[J]. Journal of Guangdong University of Technology, 2014, 31(02):49-53.
- [4].Lai Yihan, Wang Kai. Design of a Dual Wheel Balanced Vehicle Control System Based on MPU6050[J]. Journal of Henan Institute of Engineering (Natural Science Edition), 2014, 26(01):53-57.
- [5].Han Danxuan, Wang Fei. Application Research of DHT11 Digital Temperature and Humidity Sensor[J]. Electronic Design Engineering, 2013, 21(13): 83-85+88.

The first author, Wang Weiqi, December 28, 1995, School of Electronic Information, Jiangsu University of Science and Technology, Electronic Information Science and Technology, Native Place: Zhangjiakou City, Hebei Province