

---

DOI: <https://doi.org/10.53555/eijse.v6i1.13>

---

## DESIGN CONTROL SYSTEM SHIP STABILITY CORVETTE SIGMA-366 HASSANUDIN USING LINEAR AND NONLINEAR WITH WATER WAVE SEA STATE 6

**Devina Puspita Sari<sup>1\*</sup>**

*\*<sup>1</sup>Ship Building Engineering Department, Politeknik Perkapalan Negeri Surabaya ITS, Keputih Sukolilo Surabaya 60111*

**\*Corresponding Author:**

---

### **Abstract:-**

*Many disaster due to the magnitude of disturbance sea waves behind a study on the stability control system rolling corvette warship KRI Hassanudin SIGMA-366. In this study a comparison between dynamics modeling warship approach Nomoto linear and nonlinear Hamamoto. Fuzzy logic control is used Takagi Sugeno. KLF have two inputs, error heading and yaw rate. External disturbances such as waves disturbances sea state six. With the wave disturbances, response control rolling stability to longer than no disturbances. Response actual stabilization test and simulation rolling with input heading  $20^{\circ}$  and  $30^{\circ}$  in according to the standards of IMO (International Maritime Organization). The results of the modeling system performance stability control ship when the sea state is given disturbance wave six conducted by Nomoto linear method is better than the nonlinear state space Hamamoto method. Maximum overshoot generated by a closed loop system with linear and nonlinear wave disturbances have met the criteria with a maximum system stability overshoot twice before returning to a steady state with a maximum of time 18 seconds.*

**Keywords:-** *Nomoto linear, nonlinear Hamamoto, KLF, rolling, wave disturbances*

## 1. BACKGROUND

Geography Indonesia tangible form of an archipelago consisting of approximately 13,000 large and small islands scattered in the territorial waters. With water conditions are very broad, making Indonesia the country prone to piracy and pirates, illegal fishing by foreign vessels in Indonesian waters, as well as the susceptibility of the border conflict in waters with neighboring countries. Through the Department of Defense in cooperation with the Indonesian Navy in the efforts to defend the territorial integrity of NKRI to operate military warships to patrol maritime security to all Indonesian waters. One type of warship Indonesia SIGMA class imported from the Netherlands is Warship Hassanudin-366. The ship was commissioned by the Navy Fleet base to Indonesia in 2007. The ships of this type including the newest vessels that are currently often operate in the waters around Indonesia and has the weapons systems such as missiles (missiles) and 76 cannons on the front side of the upper middle-diameter 76 mm. This vessel has a rudder that is able to work synkron (unidirectional) and independent (different directions) as the steering system. When in operation, it has a standard Warship critical point roll stability conditions ships that are heading angle of  $30^0$  and sea state 6 with a wave height of 6 meters. If the condition of the ship is at more than 300, the heading angle of the ship's condition affected by the danger of drowning. So far critical condition corvette class warships SIGMA-366 type Hassanudin occurred twice, in 2007 and 2013. In 2007, while traveling from the Netherlands to Indonesia occurred around the wind storm in the North Sea that caused the warship suffered rolling ship reaches 24o sea state 6 and the waves reached a height of 6 meters above sea level [Director General of sea, 2011]. This condition lasted for several hours until the ship can reach a point of stability. In 2013, an interruption storms and waves as high as 6 to 7 meters around the Red Sea and the Arabian Sea for approximately 3 hours. Therefore, the stability control system on the ship was very necessary to cope with the danger of the ship sinking.

## 2. Method

The stages of data processing performed in this study can be described in the following flowchart

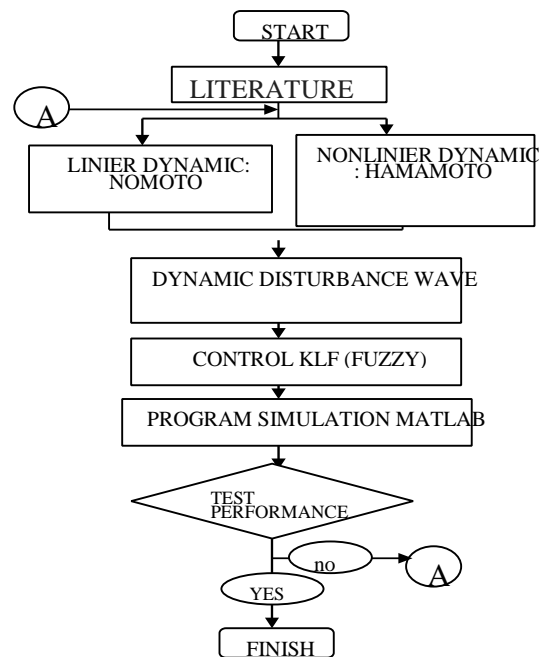


Figure 3.1 Flowchart Diagram Research

The study of literature in the form of theoretical understanding and geography of zones free shipping in the waters, covering navigation, cruise trajectory, the amount of external noise disturbance around the waters of the sea wave sea state 6. Modeling the dynamics of wave interference is calculated based on data from a height of sea waves most Extreme is 6 meters. Ship dynamics modeling is done using a linear approach Nomoto and will be compared using a nonlinear approach Hamamoto method.

Fuzzy logic control system design is made to perform the control input is the rudder angle and yaw rate. Then test the performance of the control system using simulations and compare the best method used determines the dynamics SIGMA corvettes Hassanudin-366.

### 3. Sigma corvete hassanudin-366

Spesification SIGMA Hassanudin-366 is:

LOA	= 90,71 meter
Wide (B)	= 13,02 meter
Displacement (M)	= 1818 Ton
depth ship (t)	= 3,50 meter
Speed of ship (U)	= 18 Knot atau 9,53m/s
CB	= $m / (LOA * B * T) = 0,44$
enter of gravity (XG)	= 2,1 meter
rho	= 1014 Kg/m <sup>3</sup>

Rudder type Van Amorengen

### 4. DATA ANALYSIS

#### 4.1 Analysis control ship with model dynamic Nomoto

##### 4.1.1 Dynamic Model Nomoto

Model ship dynamics based on the approach taken by Nomoto (1957) as a form of mathematical order 1 and 2 (Fossen, 1994). Here's a transfer function Nomoto :

$$\frac{r}{\delta_R}(s) = \frac{K_R(1+T_3s)}{s(1+T_1s)+(1+T_2s)} \dots\dots\dots(4.1)$$

The parameters of the transfer function is obtained from the above Nomoto

$$T1.T2 = \frac{\det(M)}{\det(N)} \dots\dots\dots(4.2)$$

$$T1 + T2 = \frac{n11m22+n22m11-n12m21-n21m12}{\det(N)} \dots\dots(4.3)$$

$$KR = \frac{n21b1-n11b2}{\det(N)} \dots\dots\dots(4.4)$$

$$KR.T3 = \frac{m21b1-m11b2}{\det(N)} \dots\dots\dots(4.5)$$

$$\frac{r}{\delta_R}(s) = \frac{306.67289+1201.19052S}{S+8.94783S^2+33.0462S^3} \dots\dots\dots(4.6)$$

##### 4.1.2 System Control stability with Close Loop

Close loop stability system consisting of controllers, actuators, systems dynamics and transmitter ship. In this study, the fuzzy logic controller acts as the system controller, as the rudder actuator, system dynamics vessel (linear and nonlinear), roll damper as reducing roll motion and gyrocompass as a transmitter. Fuzzy Logic Control is designed to provide a signal rudder so that the rudder can work optimally. Done with the ship dynamics modeling approach Nomoto linear and nonlinear Hamamoto with a decrease in nonlinear state space is then performed linearization into a linear state space matrix.

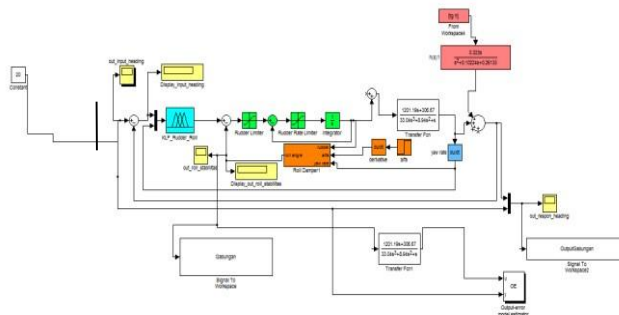
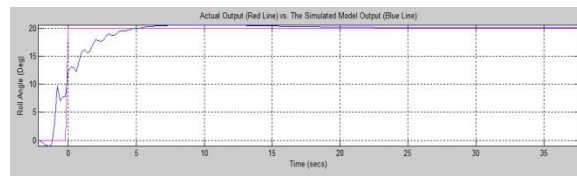
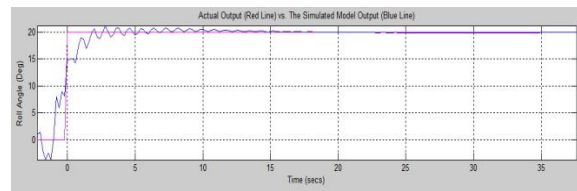


Figure 4.1 Diagram Stability Rolling Simulation by Wave Interference Sea State 6 with linear dynamics modeling ship

**4.1.3 Analysis with disturbance wave in Sea State 6** Form close loop testing systems consist of a step function input (heading  $20^{\circ}$  and  $30^{\circ}$ ), as the rudder actuator control system, ship dynamics system, roll stability control damper as rolling and controller using fuzzy logic control.

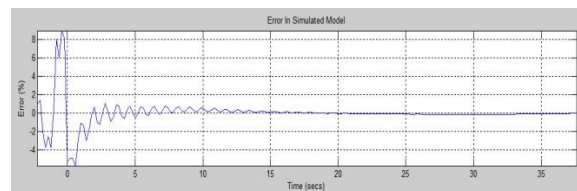


**Figure 4.2 Roll Response Simulation Test System Actual and Estimated time Heading  $20^{\circ}$  and Without Disruption**

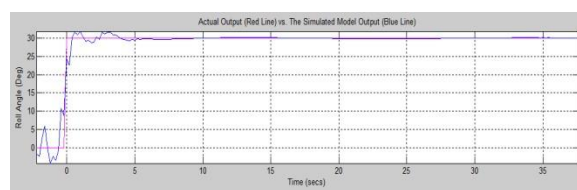


**Figure 4.3 Roll Response Simulation Test System Actual and Estimated time Heading  $20^{\circ}$  and Disturbance Wave Sea State 6**

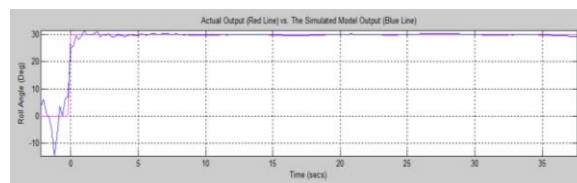
In Figure 4.2 shows the response of the actual roll simulation tests and the estimation of the current system of headings  $20^{\circ}$  and without interruption, where the roll angle of a maximum of 20.050 when the speed of the warship 18 knots or 9.53 m/s. No overshooting and reached steady state after 7 second. In Figure 4.3 shows the response of the actual roll simulation tests and the estimation of the current system of headings  $20^{\circ}$  and interference wave sea state 6, wherein the roll angle of a maximum of 20.060 when the speed of the warship 18 knots or 9.53 m / s. No overshooting and reached steady state after 15 second. It shows the presence of interference waves with a height of 6 meters, the deceleration control system built to achieve steady state conditions for 8 second. Figure 4.4 shows the response time of the system error heading  $20^{\circ}$  and wave disturbances sea state 6, in which the largest error% to 10% and 0% error immediately reached after 15 second.



**Figure 4.4 Response time of Heading System Error  $20^{\circ}$  and Disturbance Wave Sea State 6**

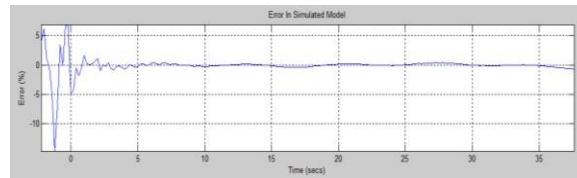


**Figure 4.5 Response Roll Simulation Test System Actual and Estimated time Heading  $30^{\circ}$  and Without Disturbance**



**Figure 4.6 Roll Response Simulation Test System Actual and Estimated time Heading  $30^{\circ}$  and Wave Interference Sea State 6**

In Figure 4.5 shows the response of the actual roll simulation tests and the estimation of the current system of headings  $30^0$  and without interruption, where the roll angle of a maximum of  $30.20$  when the speed of the warship  $18$  knots or  $9.53$  m / s. Overshoot occurs twice (less good) then reach the steady state at the time of  $8$  second. In Figure 4.6 shows the response of the actual roll simulation tests and the estimation of the current system of headings  $30^0$  and wave disturbances sea state  $6$ , in which the roll angle of a maximum of  $30.050$  when the speed of the warship  $18$  knots or  $9.53$  m / s. No overshooting and reached steady state after  $10$  second. It shows the presence of interference waves with a height of  $6$  meters, the deceleration control system built to achieve steady state conditions by  $2$  second. Figure 4.7 shows the response of a system error when heading  $30^0$  and wave disturbances sea state  $6$ , in which the largest error%  $15\%$  and soon reach  $0\%$  error after  $10$  seconds (the response is less well). Based on the results of the response seen that the smallest error% when given a heading of  $20^0$ , while the longer time it takes  $5$  seconds when given a heading of  $20^0$  (figure 4.3).



**Figure 4.7 Response time of Heading Error  $300$  and Wave Interference Sea State  $6$**

## 4.2 Analysis Simulation Results Stability Control System (Rolling) Approach Nonlinier Hamamoto

### 4.2.1 Dynamic Model Nonlinier Hamamoto

Modeling the dynamics of the ship using nonlinear equations with mathematical models used by Hamamoto and Kim (1993) and Hamamoto, et al (1994). Where  $5$  degrees of freedom (DOF), among others, surge, sway, roll, pitch and yaw converted into state space equation. Before being converted to state space equation.

Then the nonlinear equations 4.7 and 4.8, and the similarities 4:13 until 4:14 first equation simplification by grouping created by members of the same variables, as follows:

$$\text{Surge : } m(\dot{u} + v\dot{\psi}) - (my - Xv\dot{\psi})v\dot{\psi} + mx\dot{u} + m_z w\dot{\theta} = X_\delta \delta \dots \dots \dots (4.7)$$

$$\text{Sway : } (m + m_y)\dot{v} + Y_{\dot{v}}\dot{v} = -Y_v v + Y_{\dot{v}}\dot{v} + Y_\delta \delta \dots \dots \dots (4.8)$$

$$\text{Roll : } (I_{xx} + J_{xx})\ddot{\theta} - (I_{xx} + J_{xx})\dot{\theta}\dot{\psi} + K_\delta \ddot{\theta} + z_G \cdot Y_{\dot{\psi}}\dot{\psi} = Y_v v + K_\delta \delta \dots \dots \dots (4.9)$$

$$\text{Pitch : } I_{yy}\ddot{\theta} - I_{xx}\dot{\psi}\dot{\theta} + J_{xx}\dot{\psi}\dot{\theta} + J_{yy}\ddot{\theta} = -M_{\dot{\theta}}\dot{\theta} - M_\theta \theta - M_w \dot{w} - M_w w + M_\delta \delta \dots \dots \dots (4.10)$$

$$\text{Yaw : } N_{\dot{\psi}}\dot{\psi} + (I_{zz} + J_{zz})\dot{r} = (-N_v - Y_v x_G)v + (-N_{\dot{\psi}} - Y_{\dot{\psi}} x_G)r + N_\delta \delta \dots \dots \dots (4.11)$$

$$\text{Yaw.dot = kecepatan yaw : } \dot{\psi} = r \dots \dots \dots (4.12)$$

$$\text{Roll.dot = kecepatan rolling : } \dot{\theta} = g \dots \dots \dots (4.13)$$

$$\text{Pitch.dot = kecepatan pitching : } \dot{\theta} = f \dots \dots \dots (4.14)$$

Where  $m$  is the mass of the ship,  $m_x$ ,  $m_y$ , and  $m_z$  is the addition of mass to the axis  $x$ ,  $y$  and  $z$ . While  $I$  is the moment of inertia of the mass of the ship,  $I_{xx}$ ,  $I_{yy}$ , and  $I_{zz}$  is the addition of the inertial mass moment of the ship to the direction of the  $x$ ,  $y$  and  $z$ . Similarly,  $J_{xx}$ ,  $J_{yy}$  and  $J_{zz}$  is the moment of inertia of the directions  $x$ ,  $y$  and  $z$ . Speed surge, sway and heave defined by  $u$ ,  $v$ , and  $w$ . Meanwhile, displacement roll, pitch and yaw is defined by  $\phi$ ,  $\theta$ , and  $\psi$ .  $T$  is the propeller thrust,  $R$  is the resistance propeller. then,  $t_p$  is thrust deduction coefisient.  $x_G$  is the center of gravity is the center point of the mass of the ship. And  $g$  is the acceleration of gravity. In Equation 4.9 and 4.11 is the hydrodynamic coefficients are based on the discovery of Kim, et al, Input consists of several input variables, among others, heading error ( $e$ ) and yaw rate ( $r$ ). While the (3.6) output of rudder angle. Membership functions for (3.7) input variables error heading and yaw rate is 3 membership function with a triangular (3.8) shape consisting of NB (Negative Big), NM (Negative Medium), NS (Negative Small), Z (Zero), PM (Positive Medium), PS (Positive Small), and PB (Positive Big)

which were solved using the calculation method of Frank-close fit. Koefisisen roll damping, which is calculated by the equation  $K_\phi$  found by Takahashi (1969). Then it may be written using a matrix of nonlinear state space model of the decline Hamamoto, as follows:

$$\begin{bmatrix}
 m + m_x & 0 & 0 & m_x v & -m_x v - m_y v + x_r \dot{\psi} & 0 & 0 & 0 & 0 \\
 0 & m + m_y & 0 & 0 & -m_x u + m_y u & 0 & 0 & 0 & 0 \\
 0 & 0 & k\phi & 0 & -I_{xx}\dot{\theta} - J_{xx}\dot{\theta} + y\dot{\psi}Zg & 0 & I_{xx} + J_{xx} & 0 & 0 \\
 0 & 0 & -I_{xx}\dot{\psi} & 0 & -J_{xx}\dot{\theta} & 0 & 0 & I_{yy} + J_{yy} & 0 \\
 0 & n_x & I_{xz}\dot{\theta} + J_{xz}\dot{\theta} & 0 & 0 & 0 & I_{xz} + J_{xz} & 0 & 0 \\
 0 & 0 & 0 & 0 & 0 & 1 & 0 & 0 & 0 \\
 0 & 0 & 0 & 0 & 0 & 0 & 0 & 0 & 0 \\
 0 & 0 & 0 & 0 & 0 & 0 & 0 & 0 & 0 \\
 0 & 0 & 0 & 0 & 0 & 0 & 0 & 0 & 0 \\
 0 & 0 & 0 & 0 & 0 & 0 & 0 & 0 & 0
 \end{bmatrix}
 \begin{bmatrix}
 \dot{u} \\
 \dot{v} \\
 \dot{\phi} \\
 \dot{\theta} \\
 \dot{\psi} \\
 \dot{r} \\
 \dot{p} \\
 \dot{q} \\
 \dot{f}
 \end{bmatrix}
 =
 \begin{bmatrix}
 0 \\
 0 \\
 0 \\
 0 \\
 0 \\
 0 \\
 0 \\
 0 \\
 0 \\
 0
 \end{bmatrix}
 +
 \begin{bmatrix}
 X \\
 Y \\
 K \\
 M \\
 N \\
 O \\
 P \\
 Q \\
 R
 \end{bmatrix}
 \tag{4.15}$$

and produces the matrix A and B to be used for modeling the dynamics of the ship, as follows:

$$A = \begin{bmatrix}
 0 & 0 & 0 & 0 & 0 & 0 & 9.53 & 0 & 0 \\
 0 & -1611.25 & 0 & 0 & 0 & 0 & 0 & 0 & 0 \\
 0 & 0 & 0 & 0 & 0 & 0 & 0 & 1 & 0 \\
 0 & 0 & 0 & 0 & 0 & 0 & 0 & 0 & 1 \\
 0 & 0 & 0 & 0 & 0 & 0 & 1 & 0 & 0 \\
 0 & 34.04 & 0 & 0 & 0 & 0 & 0 & 0 & 0 \\
 0 & -0.16 & 0 & 0 & 0 & 0 & 0 & 0 & 0 \\
 0 & 0 & 0 & 0 & 0 & 0 & 0 & 0 & 0
 \end{bmatrix}
 \tag{4.16}$$

$$B = \begin{bmatrix}
 0 \\
 -1590.77 \\
 0 \\
 0 \\
 0 \\
 -39.34 \\
 -0.01 \\
 0
 \end{bmatrix}
 \tag{4.17}$$

(3.3)

#### 4.2.2 Logic Control the Design of Control System Using Fuzzy

Fuzzy logic control results can be seen from the rule base as shown in Table 4.1. The knowledge base contains the database (data base) and the rules of the rule base (rule base).

**Table 4.1 Rule Base Fuzzy Logic Control**

e*/r	NB	NM	NS	Z	PS	PM	PB
NB	Z	PS	PM	PB	PB	PB	PB
NM	NS	Z	PS	PM	PB	PB	PB
NS	NM	NS	Z	PS	PM	PB	PB
Z	NB	NM	NS	Z	PS	PM	PB
PS	NB	NB	NB	NS	Z	PS	PM
PM	NB	NB	NB	NM	NS	Z	PS
PB	NB	NB	NB	NB	NM	NS	Z

The database serves to define sets of fuzzy from the input signal and the output signal to be used by linguistic variables in the rule base. The database used in this study based on the expertise and research related to rudder roll stability system.

#### 4.2.3 Disturbance Modeling Ships Sea State 6 with a height of 6 meters

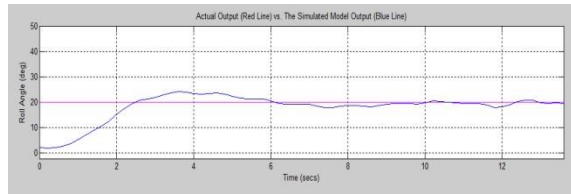
The results of modeling the transfer function of wave interference Sea State 6 with a height of 6 meters, as follows: wave Height H = 6 meters

Wind velocity v = 16.837 m / s

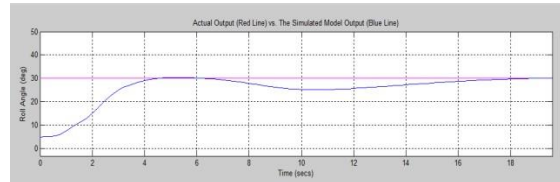
$$\begin{aligned}
 \omega_0 &= 0.4\sqrt{g/h} \\
 \omega_0 &= 0.4\sqrt{\frac{9.8}{6}} \\
 &= 0.51221 \\
 K\omega &= 2\xi\omega_0\sigma_\omega \\
 &= 0,10224 \times 3,16 = 0,3230784 \\
 h(s) &= \frac{0,3230784s}{s^2 + 0,10224s + 0,26133} \dots\dots\dots(4.18)
 \end{aligned}$$

#### 4.2.4 Results without Waves Sea State 6

Desired output response is a roll angle. Close loop system consists of a step function input, as the rudder actuator control system, and the system dynamics Corvette Warships Hassanudin SIGMA366, roll stability control damper as rolling and controller using fuzzy logic control.



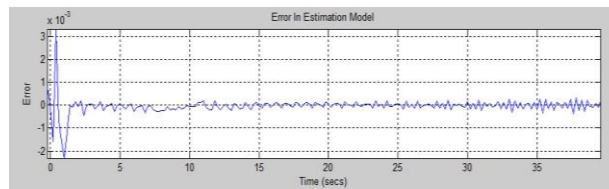
**Figure 4.8 Response Roll Currents Simulation Test and Estimation System Uninterruptible time Heading 200**



**Figure 4.8 Response Roll Currents Simulation Test and Estimation System no disturbance Heading 300**

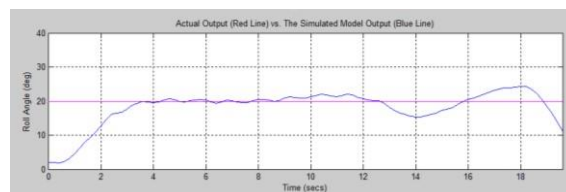
Figure 4.8 shows the response of the actual simulation tests and the estimation without interruption when a heading of  $20^0$ , in which the roll angle of a maximum of 24.030 when the speed of the warship 18 knots or 9.53 m / s. Overshoot that occurs is 1 times and then reach the steady state at the time 18 second. Figure 4.9 shows the response of the actual simulation tests and the estimation without interruption when a heading of  $30^0$ , in which the roll angle of a maximum of 30.480 when the speed of the warship 18 knots or 9.53 m / s. Overshoot that occurs is 1 times and then reaches steady at 18 sekon. Saat given a heading of  $30^0$  entries, the response produces better performance (according to the target set points heading). When compared to when given a heading of  $20^0$  entries have fairly high overshoot and not smooth.

When compared with the writer R. Sutton and GN Roberts, rolling stability test results at a given input heading and speed rate of 1.50 warships at 12 knots (6353 m/s), producing a roll angle of 40 (overshoot that occurs is 2 times) , At the 50 second response time has reached steady state. It is clear that the control system is built on research (Figure 4.8, Figure 4.9 and Figure 4.12) still has a better performance when compared with the results of R. Sutton and G. N. Roberts.



**Figure 4.10 Error Response Simulation Test System Actual and Estimated Without Interference with Heading for 300**

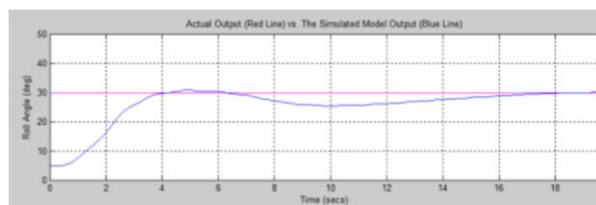
Response error between actual and estimated simulation is shown in Figure 4.10. The maximum error is 0.003320 and the standard deviation of the average is equal to 0.05350. This shows that the system is still within the tolerance limits are permissible. At 4.11 the figure shows the roll response simulation test of actual and estimated current system of headings and wave disturbances sea state 6, in which the roll angle of a maximum of 25.00 when the speed of the warship 18 knots or 9.53 m / s. Overshoot that occurs is as much as two times before returning to the steady state at any time after 20 second.



**Figure 4.11 Response Simulation Test Roll Actual and Estimated time Heading System 200 and Disturbance Wave Sea State 6**

In figure 4.12 shows the response of the actual roll simulation tests and the estimation of the current system of headings  $30^0$  and wave disturbances sea state 6, in which the roll angle reaches a maximum of 30.050 and the overshoot that occurs is 1 times before returning to the steady state at a time over 18 second. This suggests that the best response overshoot is at an angle heading  $30^0$  (Figure 4.12).





**Figure 4.12 Response Simulation Test Roll Actual and Estimated current system Heading 30<sup>0</sup> and Wave Interference Sea State 6**

## 5. Conclusion

After testing the stability control system design with input close loop heading 20<sup>0</sup> and 30<sup>0</sup> on the ship dynamics modeling approach Nomoto linear and nonlinear Hamamoto, then his performance rudder roll stabilization systems obtained are as follows:

1. Modeling the ship using a linear approach Nomoto when given a heading of 20<sup>0</sup>, produced a maximum% response results with an error of 10% and 0% error immediately reached after 15 second. When given a heading of 30<sup>0</sup>, produced a maximum% response results with an error of 15% and 0% error immediately reached after 10 second. It shows that when a heading of 20<sup>0</sup> produces the smallest error%% error margin of 5% and require a longer time for 5 seconds when compared to the current heading 30<sup>0</sup>.
2. Maximum overshoot generated by a closed loop system with linear and nonlinear wave disturbances have met the criteria with maximum system stability overshoot twice before returning to a steady state with a maximum of 18 seconds of time.
3. The results of the modeling system performance stability control ship when the sea state is given disturbance wave 6 conducted by Nomoto linear approach is better than the approach of nonlinear state space method Hamamoto, indicated that the overshoot produced less and quickly respond back to state stabilized (steady state) with a minimum of 10 second and 15 second maximum.

## Bibliography

- [1]. Amerongen, J. Van, Klugt, P.G.M.Van Der, Lemkes, H.R. Van Nauta., 1990. *Rudder Roll Stabilization for Ships. Automatica, Vol. 26, No.4, pp 679-690: Pergamon Press pic*
- [2]. Barrass, C.B., dan Derrett D.R., 1999. *Ship Stability for Masters and Mates. ButterworthHeinemann.*
- [3]. Fossen, Thor.I. 2005. *A Nonlinear Unified State-Space Model for Ship Maneuvering and Control in a Seaway. Journal of Bifurcation and Chaos, Department of Engineering Cybernetics, Norwegian University of Science and Technology. Norwegian.*
- [4]. Fossen, Thor. I. dan Ola-Erik Fjellstad., 1995. *Nonlinear Modelling of Marine Vehicles in 6 Degrees of Freedom. Journal of Mathematical Modelling of Systems, Vol. 1, No. 1.*
- [5]. Himam, M. Faikhul. (Letda Laut), 2013. *Kri Sultan Hasan din 366.ppt-Satuan Kapal Eskorta Ko-Armatim. Surabaya.*
- [6]. Roger Skjetne dan Fossen Thor I., 2001. *Nonlinear Maneuvering and Control of Ships. Department of Engineering Cybernetics, Norwegian University of Science and Technology Norwegian*
- [7]. R. Sutton, G. N. Roberts dan S. R. Dearden., 1989. *Design study of a fuzzy controller for ship roll stabilisation. Electronics & Communication Engineering Journal.*