

LIGHT REMOTE CONTROL THROUGH MULTI-CHANNEL BY CLOUD PLATFORM BASED ON NETWORK

Zhang Xin^{1*}

¹Jiangsu University Academy of electrical and information engineering, Zhenjiang, Jiangsu Province, 212003

***Corresponding Author:-**

Abstract:-

This paper analyses the present situation of the development of networking and smart home. Rapid development of the Internet and smart home. Because these technologies are making people's lives more convenient, so loved by people. Using the embedded control technology, by means of infrared technology and WiFi networks, set up a remote to control the lighting system. Using this system, users can use the smart device to control the lighting. You can also view the current lighting condition. Greatly enriches the way lights are used.

Keywords:- *Embedded technology; remote control; infrared; WiFi; lighting; smart home; TCP/IP*

CLC number: TP368 Literature identification code: B

1 INTRODUCTION

At present, the technology related to electronic technology has made great progress. As electronic technology was very important, it has deep national economic development and all aspects of production and people's daily life. With the advent of smart phones in recent years, network technical developing, also began to more and more rapid development of Internet of things.

Light is very important in our daily life for daily use. Since the lamp was invented, greatly promoted the development of all mankind. With the development of science and technology, the concept of Internet of things was put forward and widely known. Thus, electronic technology combined with traditional lighting, is very useful.

Embedded technology, has been a huge development in recent years. Not just pure technology development, embedded in the areas covering almost all common electronic devices.

Embedded in one of the outstanding products in recent years, almost everyone has a Smartphone. In addition, in the automotive sector, satellite navigation, space technology, industrial production and other fields, will be able to see figures for embedded devices. It can be said that embedded technology with our modern life are inseparable.

STM32 chip is developed by STMicroelectronics. STM32F103 series which is a common medium-performance processor. It uses ARM's high performance "Cortex-M3" kernel, can meet the needs of most small embedded devices. Is the system used in embedded control main control chip?

This system combines infrared and WiFi communications technologies, using these two technologies into a common lighting controls, established a system of remote-controlled lighting.

Hardware circuit board design using Altium Designer. Software development using the Keil software using the C programming language based STM32 official library file using mature technology of infrared technology and WiFi networking technology communication. Users can use the traditional control with infrared remote control device or smart phone. We can design an Android application can query the status lights, greatly improving the use-friendliness, and made the device very easy to use.

2. Embedded control technology

2.1 STM32 chip General information

STM32 chip is developed by STMicroelectronics company products. It is the use of ARM Cortex-M3 kernel. The ARM Cortex-M3 kernel is designed for high performance, low cost, low power consumption embedded applications. It has integrated embedded Flash and SRAM processors and it is a 32-bit processor. Compared with the 8/16 device, an obvious advantage, not only speed improved, and a higher efficiency of code execution.

We are using a STM32F103ZE chip.

Because it contains the ARM kernel, so it can be compatible with all ARM tools and development platforms and has a very good compatibility. Its performance is very strong, the maximum operating frequency of up to 72MHz, 512K bytes of Flash program memory, 64K bytes of SRAM. And there is power management, low power, analog-digital converters, DMA. There are plentiful timers, interrupt Manager, supports multiple communication protocols such as CAN, usart, SPI, I2C. Peripherals are strong. STMicroelectronics provides library development files. Encapsulate frequently used peripherals driver code, developer at the time of use, only need to call certain parts and modify some parameters, it can be used. This library file, after several generations of optimization and maintenance, now have a very stable, high code efficiency, writing style is also acceptable, while officially supporting a wealth of library development manual, help developers use development methods base on the library for the preparation and operation. And because most developers are developing with this set of libraries, so between different programs, code portability is very high.

Due to different STM32 family is using the same set of software development, so that different types of compatibility between STM32 is relatively high.

2.2 RGB lamp profile

RGB light is a bulb which encapsulates the three colors of the lights, the three colors are the primary colors of light, red (R), green (G), blue (B). By controlling the three lights of mixing, you can show a variety of colors. Using LED lights. LED lighting is the full name of Light Emitting Diode. It is made with Gallium (Ga), arsenic (As), phosphorus (p) and nitrogen (n) compounds, such as steel. It is also a semiconductor diode, formed by a PN junction.

When the light emitting diode with forward voltage, injected from p to n holes and n into pelectronic, in the vicinity of PN junction within a few microns respectively with n electrons and p-holes combined, resulting in spontaneous emission of fluorescence. Different semiconductor materials, electrons and holes in the different energy States, when the electron and hole composite release energy much different. Release more energy, the shorter the wavelength of the light emitted. So they make all kinds of different colors of light.

From 1990s till now, LED technology has a great deal of progress. Its luminous efficiency (60%), far more than the incandescent lamps (10%), light intensity also meets the needs of most life situations. But also has a wealth of colour, compact size, service life (100,000 hours) also far exceeds that of other luminaires.

2.3 Introduction to infrared control

Infrared remote control transmitter is the use of infrared light emitting diode to emit modulated infrared light; infrared receiver the infrared receiver diodes, transistors or silicon photovoltaic cells, they convert infrared light IR launchers corresponding electrical signal, then sent the amplifier.

General instructions of the transmitter key (or joystick), instruction coding, modulation circuits, circuit, circuit consists of several parts. When you press the command key or when the push lever, instruction coding circuit instructions coded signals required, instructions encoded signal to modulate the carrier, consists of a driving circuit for power amplification by the transmitter after outward through adjusting the set of instructions coded signals.

Receiver General receiver, amplifier, circuit, instruction decoder circuit, driving circuit, perform the circuit consists of several parts. Receiving modulated coded instructions given by the transmitter signal received, sent after amplification and demodulation circuit, demodulator instruction encoding signal modulation and demodulation, and revert to the coded signal. Instruction decoder encoded instruction signal decoding, and finally by the driver to drive the implementation of circuit instructions operation control.

3 Network communication technology

3.1 WiFi module introduction

With the rise of mobile devices over the years, WiFi technology has become a necessity in modern life. Wi-Fi is a technique that allows electronic devices to connect to a wireless LAN (WLAN) technologies, usually using the 2.4G or 5G SHF UHF ISM radio frequency band. At this stage, almost all smart phones, laptops, and Tablet PCs support the use of WiFi Internet access. Is currently one of the most widely used wireless network transmission technology.

We use the WiFi module is ESP8266 ESP8266 high-performance wireless SOC. ESP8266 is a complete and self-contained solution for WiFi network, and can run on its own, can also be run as a slave to carry to other Host. ESP8266 can pick up applications. Only when it served as the device application processor, launch it directly from an external flash. Built-in cache memory to improve system performance and reduce memory requirements.

Another scenario is that when the wireless Internet access in the task of WiFi adapter, you can add it to any microcontroller-based designs, connection is simple, simply by SPI/SDIO or CPU AHB bridge interfaces can be.

ESP8266 powerful on-chip processing and storage capacity, so that it can be integrated specific sensors and other application's equipment by GPIO port, achieving the lowest early in the development and operation of take up a minimum of system resources.

ESP8266 high level of chip integration, including antenna balun, power management converter, so only minimal external circuitry, and the entire solution, including the front-end module minimizes PCB space occupied by at design time.

With ESP8266 of leading system features include: energy-saving VoIP in your sleep/wake pattern between the quick switche combined transferred to the destination. IP-Internet with low power Adaptive radio operation bias, Protocol, in short, is for each piece of equipment front-end signal processing functions, provides continuous access to the Internet for a troubleshooting and coexistence characteristics address, which it says data destination.

In order to eliminate cellular/radio system Bluetooth/DDR/LVDS/LCD interference

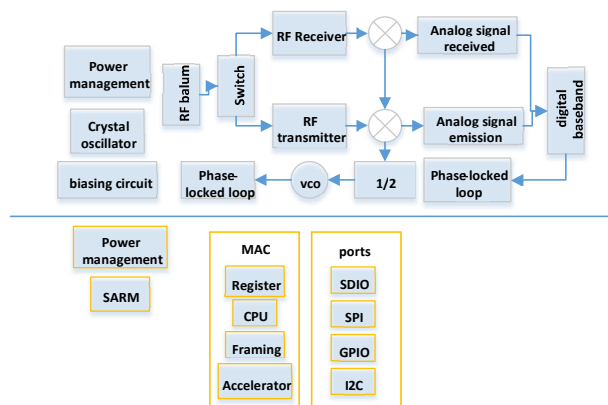

FIG 1 ESP8266 module diagram

3.2 Introduction to TCP/IP protocol

TCP/IP Protocol, full name is the Transmission Control Protocol/Internet Protocol. TCP/IP protocol is the Foundation of the Internet. Is the most basic Internet protocols. It is composed of two parts, an IP is a network layer protocol, and the other is the TCP transport layer protocol.

TCP/IP protocol is not both the TCP and IP protocols collectively, but the Internet TCP/IP protocol family as a whole. Protocol layering model, TCP/IP consists of four layers: the network interface layer, network layer, transport layer, the application layer.

TCP/IP defines how electronic devices connected to the Internet, as well as the criteria for how data is transferred between them. TCP is to control information transmission, mainly to check the accuracy of information transmission. Once you send data error is detected, will issue instructions, command error data stream transmission, until all data is correctly Transferred to the destination. IP-Internet Protocol, in short, is for each piece of equipment provides continuous access to the Internet for an address, which it says data destination.

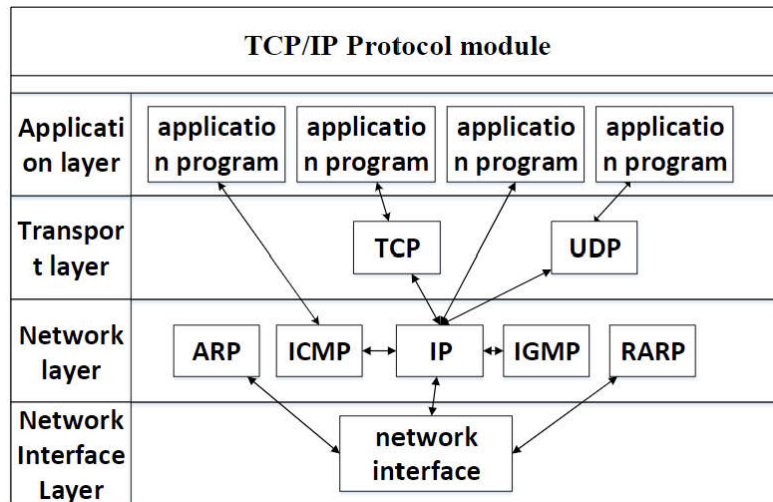

FIG 2: TCP/IP Protocol module

4 System Design

4.1 System Overview

This system contains LED lights, STM32 chip system, infrared remote control modules, ESP8266 modules, mobile phone applications.

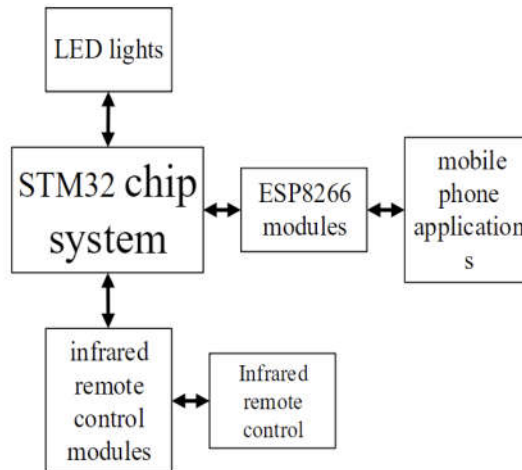

FIG 3: System architecture diagram

4.2 System Hardware Design

STM32 minimum system is used as a central processing unit in the control system. STM32 minimum system needs to drive RGB light modules, infrared remote control module and ESP8266 module.

STM32 minimum system is in the case of STM32 chip running, most streamlined system circuit design. STM32 minimum system typical circuit: STM32 chip, power supply circuit, clock, reset circuit, startup configuration and download circuit STM32 chip voltage between

2.0V~3.6V, so to have a circuit to provide a stable power supply voltage. Chip cannot run without clocks, clocks are usually generated by a crystal oscillator that is crystal, you need a 8MHz crystal oscillator clock for the entire system, you also need to provide a 32.768kHz crystal oscillator for RTC clock. STM32 BOOT0 and BOOT1 to select the startup mode, you need to be out, through three jumpers to configure the STM32 startup mode. Chip reset needs a reset circuit, reset circuit is composed by press and protection of capacitors, resistors, power case, press system reset is triggered. In addition, the program downloads to download circuit, generally using JTAG download method.

RGB lights with LED lights, the principle is the same. Circuit in the design of RGB light LED lamp design rules are followed. Infrared remote control module and ESP8266 module is using serial communication mode, module with STM32 are connected in serial communication is OK.

4.3 System Software Design

The system software design of modular programming. Through the function modules and design of data flows between the various modules in order to maintain good readability, portability, and scalability. According to the different software functions, the system is divided into STM32 chip drive, drive and control, infrared remote control lighting module in the module control, drivers of ESP8266 network module and information transfer, serial debug host computer and Android applications, and several sections. Systems software function block diagram is shown in figure.

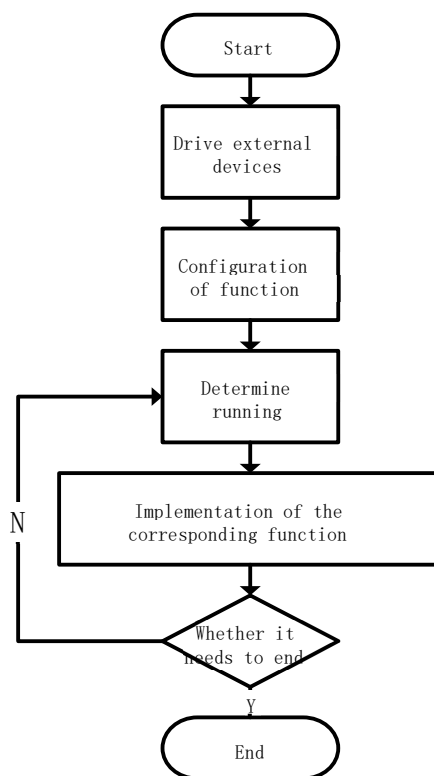

FIG 4: Systems software function block diagram

Programming of the system consists of three levels. Three layers are: hardware drivers, control functions, data exchange. Hardware drivers is to configure the chip registers, you need to use the STM32 library development. Library's role is to encapsulate STM32 chip registers, Register groups in accordance with the needs, and category as the corresponding function. At the time of using, initialize the GPIO or peripheral used, and then write the function that the hardware module needs to execute. Use this method to complete the hardware driver.

In this system, STM32 is the core controller so you need to configure STM32 first. Put the drivers and mapping files required by STM32 into the correct path to the project template and configure them in the keil development platform, you can complete the STM32 configuration, then you can add other hardware drivers.

RGB lights, infrared remote control, ESP8266 network module driver write mode similar to the above process. According to the operation mode of each of these modules, configure each GPIO pins used to prepare external timers drive, writing serial drivers, system timer driver.

Control function, that is, on the basis of the above hardware drivers, use the processor to control hardware peripherals. This part is usually called the driver inside the function, the assignment of these functions, you can make the hardware complete the corresponding action. We can accomplish what we need to control. These are generally located in the main function. By user's writing, let the hardware do the corresponding action.

Data exchange is done through an appropriate communication protocols. This data exchange system, mainly through the serial port protocol and TCP/IP protocol. Use these protocols, you need to call some pronunciation of c libraries, such as redefine in the serial driver. Through these protocols, you can complete the STM32 debug host computer communicates with the serial port, or ESP8266 with the data transfer between mobile devices, network PC.

5 System Implementation

In the Keil development platform for all code written, compiled, modules should be connected with wires to be used. Burn hex files that will be generated to the STM32 minimum system, reset, program begin running. Infrared controller button is pressed, RGB lights emit different colors of light. And the ability to get key information from the serial debug host computer and lighting information.

Use Android Smartphone to install APP, After the installation is complete, connect WiFi which is issued by ESP8266 network module, establish communication to make mobile phones and embedded control systems. This time can be seen from the phone system's overall interface. It contains the lighting control, also set aside some other custom interfaces for use by other functions. In this way, we can remote control RGB lights by phone. In addition, this is just using the embedded control systems and establish a point-to-point link between Smartphone, here you can also access the public network IP of course, use some company to build cloud servers so that you can control the lights on the system at any time. The call process: First run the STM32 system initializes serial network module, ESP8266, RGB lamps and infrared remote control device.

When using the infrared remote control device, scanner reads the infrared receiving device's interrupt flag, once the scan of the signal, began to verify and accept signals when the reception is completed, began to perform the appropriate button corresponding to the function.

When using the ESP8266 module communication, first to build a WiFi and mobile phone connected to it. And manipulation of RGB lights through the APP, these specific actions will have a set of data, and sent from the mobile phone by setting IP to the ESP8266 module.

ESP8266 received this data, the data sent through the serial port to the STM32 and RGB light control function is called to achieve control of RGB light. If you use a cloud server, reason is similar. Mobile data through the public network access to the server specifies the IP. The data sent by the server to the ESP8266 module by specifying IP, complete control.

6 Conclusion

In this paper, STM32 chip design for controller a remote lighting control system. System covers the development of STM32, RGB lighting design and driving, using infrared remote control device, ESP8266 network module and mobile application of APP-related content.

The use of Internet technology, so that users can achieve remote operation of the lights. But the significance of this article is not confined to this. Peripheral devices developed through this system, and establish the corresponding procedure in the mobile app, it can be controlled with mobile phones and other devices.

Also, if you can build a cloud server, cloud servers as a data hub, so as long as the device is connected to the network, you can connect through a cloud server for a more extensive. Extended home wireless router upgrade the processor as a coprocessor for routers, complete control, and multiple devices can be connected. This will greatly enhance the life experience.

References

- [1]. Liu Huoliang, Yang Sen. STM32 Library Development Guide. China Machine Press, 2013.5
- [2]. Li Hong, Internet of things: productivity change. The People's Posts and Telecommunications Press (Posts & Telecom Press), 2010
- [3]. Brian W. Kernighan, Dennis M. Ritchie, The C Programming Language. China Machine Press, 2004
- [4]. Zhang Yihe. The Altium Designer complete circuit the circuit diagram article. China Machine Press, 2007
- [5]. Joe Casad. Sams Teach Yourself TCP/IP in 24 Hours. Sams Publishing, 2012.