

THE RESEARCH OF HIGH-FREQUENCY POWER SUPPLY CONTROL SYSTEM BASED ON MSP430

Fan Yin^{1*}, Yuan jiang LI², Jie Zhong³, Han Yu⁴, Jing Shao⁵, Yang Yu⁶ Yang Qing⁷

^{1,3,4,5,6,7}Undergraduate Student School of Electrical and Information, Jiangsu University of Science and Technology, Zhenjiang, 212003, China.

²Associate professor School of Electrical and Information, Jiangsu University of Science and Technology, Zhenjiang, 212003, China. E-mail: 419742223@qq.com

***Corresponding Author:-**

Email: 623883086@163.com

Abstract:-

The development of power electronic devices is relatively slow. As a result, the development of the high-frequency inverter is extremely limited. This paper analyzes the characteristics of the IGBT and MSP430 and then designs a high-frequency inverter control circuit based on MSP430. The PWM control wave is outputted in software by MSP430, and the PWM wave is amplified by the driver circuit for driving the half-bridge inverter main circuit made up of two IGBT components. Controllability includes adjustable frequency, variable duty cycle and dead time variable and several other aspects of PWM waves. This design realizes reducing losses and improving the efficiency of the overall circuit purposes. Meanwhile, the other circuit configuration such as driver and protection circuits in the entire system are also made some corresponding design description. Finally, the design of the control system is made further verification by IAR software download debugging. The final results prove that PWM control circuit based on drive and protection circuits can work and the frequency, duty cycle, dead time of the PWM can be adjusted. A brief analysis about the advantages and disadvantages of the entire circuit is reported and some improved methods are also presented at the end of this paper.

Keywords:- MSP430; High-frequency inverter power; PWM control; IGBT

1. INTRODUCTION

With the development of sustainable and green development concept, the use of clean energy such as solar and wind energy are getting more and more people's attention, therefore, the photo voltaic power generation, wind power generation has been rapid development in the recent years. In these power generation technology, the inverter device not only play the role of DC to AC conversion, but also play a role in the tracking protection circuit. Inverter not only play an important role in power generation technology, but also play an important role in communication, navigation, industrial equipment, satellite communications and so on. Inverter power supply and our life are closely related [1].

Since 2000, with the development of intelligence technology and automatic control, A variety of electrical equipment have increasingly strict requirement for the stability, detect ability, controllability and other aspects of Power Supply. And more and more power facilities also has a variety of special requirements for the other parameters of the power supply. In order to enable the normal operation of these electrical equipment, the development of inverter power supply can be very convenient and fast to achieve those requirements. The application of inverter power supply has become very extensive [1]. It plays a very important role in our daily life. Therefore, the control of high frequency inverter power is also very important, only to achieve the full control of high-frequency power supply, can it be perfectly applied to all walks of life to achieve our desired goals.

Due to the development of power electronic devices is relatively slow, the development of high frequency inverter power supply has been greatly limited, the traditional control technology is the use of output voltage, current instantaneous feedback control. This kind of control circuit is simple and the technology is mature, But with the development of inverter technology, it is more and more difficult to meet the requirements of modern high-precision control, at the same time, the disadvantages of poor reliability and weak anti-interference ability are gradually revealed. PWM control technology can realize the soft switching of the power switch tube and can achieve constant frequency control, it appears to be a good direction for the development of inverter power supply. In this paper, through the analysis of the characteristics of IGBT and the application characteristics of

MSP430 Series MCU, a set of high frequency inverter power supply control system based on MSP430 is designed and implemented. A single-chip software is used to form adjustable output control PWM wave, the PWM wave is amplified by the amplifying circuit, driving half bridge inverter main circuit that is composed of two IGBT [1]. Controllable PWM wave including adjustable frequency and duty ratio variable and variable dead time etc... The system realizes the purpose of reducing the loss and improving the working efficiency of the whole circuit. At the same time, the whole system structure of other circuits, such as: drive circuit, protection circuit and so on are also introduced simply in the rest of the paper.

Finally, the control circuit is debugged and verified. The debugging results show that the PWM control circuit can work normally under the action of the drive circuit and the protection circuit. In this paper, we analyze the advantages and disadvantages of the whole circuit, and put forward some directions for future development.

2. The Basic Principle of Inverter and MSP430

The inverter technology is corresponding to the rectification technology, the commutation is to convert AC to DC, and the inverter is to convert DC to AC. As the most important and core technology of modern power electronics technology, the application of inverter technology has been closely related to people's lives [1]. The basic principle of inverter is based on the switching characteristics of power electronic devices, through the adjustment of power electronic devices to turn on and off the output AC [2]. There are many kinds of inverter power supply, and there are many kinds of inverter methods, so the structure of inverter circuit has many characteristics [3]. The following Figure is the basic working principle of single-phase full bridge inverter circuit.

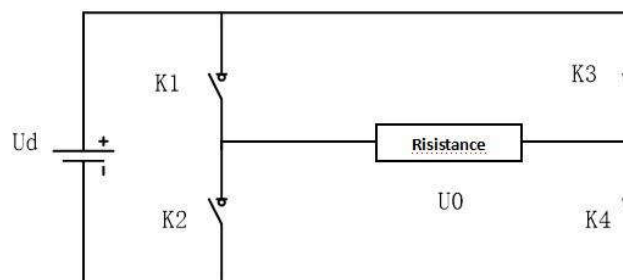

Figure 1 The schematic diagram of a full bridge inverter

The $K_1 \sim K_4$ can be regarded as 4 simplified bridges in the bridge circuit, each of which is composed of power electronic devices and other auxiliary circuits. When one of the K_1, K_4, K_2, K_3 is disconnected, the first loop is formed, and the voltage U_0 at both ends of the load is defined as positive. So when K_1, K_4 disconnect, K_2, K_3 connected, the formation of second kinds of circuit, compared with the first case of the load at both ends of the voltage U_0 is negative. Through such a circuit, switching the connection between the two sets of bridge arm can convert DC into AC. And The frequency of the alternating current can be changed by adjusting the frequency of the two bridge arms [4]. MSP430 microcontroller's applications are very extensive, In the intelligent instrument and meter, it has a good performance with small size, low

power consumption, easy to use and so on. In the industrial control, the MCU can form different control system and data acquisition system. In the field of communication network and computer, the single chip microcomputer has fully demonstrated its super intelligent control technology. In medical equipment, such as a variety of testing instruments, analyzers, diagnostic equipment, etc., have an important application of single chip microcomputer. For the study of this topic, the MSP430 F169 micro controller is chosen. The following Figure 2 is its schematic diagram [5].

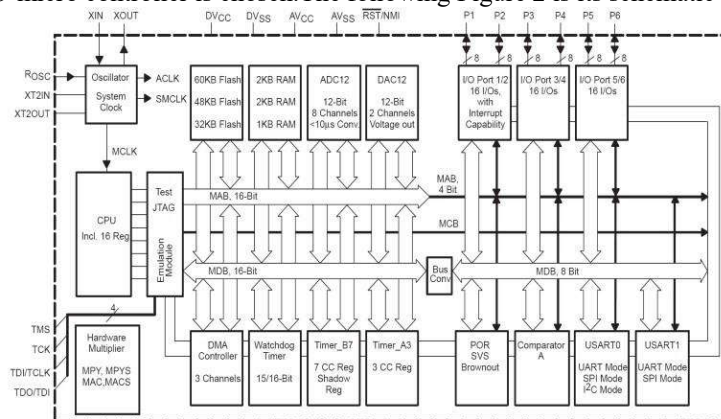

Figure 2: Schematic diagram of MSP430 F169

3. The schematic diagram of the design

The structure diagram of high frequency inverter circuit as shown in Figure 3 can be divided into three main parts: main circuit, driving circuit and auxiliary circuit. The main circuit comprises an input circuit, an inverter circuit and an output circuit. The driving circuit comprises a driving circuit and a control circuit. The auxiliary circuit comprises a plurality of protection and feedback circuits.

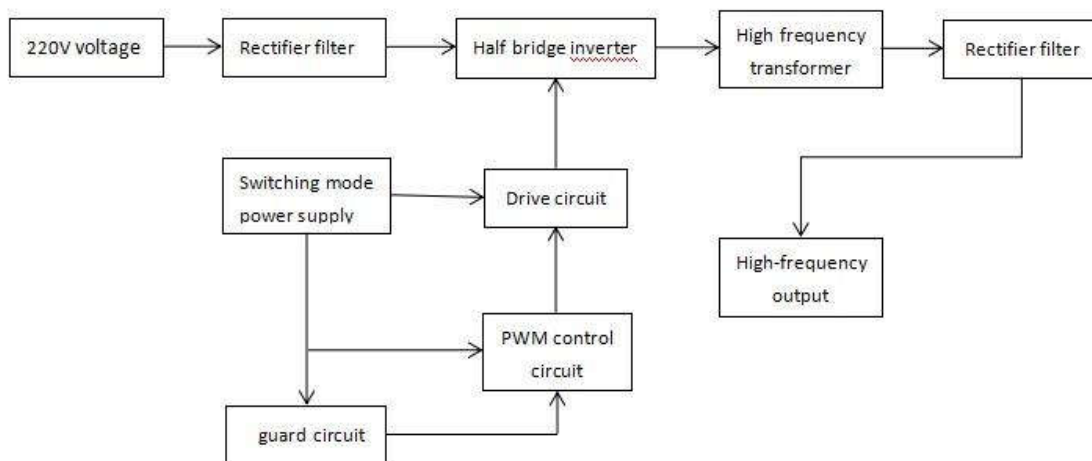

Figure 3 The circuit structure diagram

Each circuit has an indispensable role in the whole system, the following is a brief description of each circuit:

- (1) Input circuit it is the main circuit input of the inverter system. In this study, the market value of 220V is chosen.
- (2) Output circuit its main function is that the alternating current acquired by the converter transformation is dealt with the filter.
- (3) Control circuit MSP430 Series MCU is used to produce a series of control pulses to control the conduction of inverter switch, turn off frequency and realize the function of the main circuit in this study.
- (4) Inverter circuit this part is used to finish DC - AC conversion. It is the core part of the whole inverter circuit which is composed of various power electronic switching devices.
- (5) Drive circuit Because the control pulse generated by the control circuit is not enough to drive switch tube directly, the drive circuit is required to control the pulse amplification to the extent that the switch tube can be driven to Ensure the normal operation of the inverter. Q-Driver series IGBT is used in this experiment. Driver board 2QD15A17K-C, This type of drive board can be dual channel drive with built-in under voltage protection, Vce monitoring IGBT short circuit fault, Anti high frequency interference and short delay time.
- (6) Guard circuit The protection circuit is mainly to prevent the sudden breakdown of the circuit components, such as short circuit, the voltage and current suddenly burn the switch tube. It provides a safe and reliable working environment for the inverter system[6]. The basic principle of the whole inverter system as follows. The 220v/50hz will be the first to go through the rectifier filter circuit be converted into direct current. After the fly back or half bridge circuit, it will be

transformed into high frequency AC under the regulation of control pulse. Finally, the required power supply is obtained by filtering the output circuit.

4. The Experiment and result analysis

4.1 The physical simulation

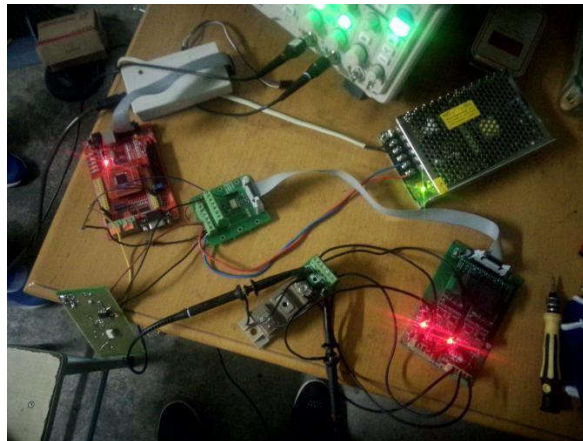

Figure 4 The Physical simulation

The entire circuit includes a switching power supply, MSP430 MCU, TC4424 MOSFET driver IC, 2QD15A17K-C driver board and the half bridge inverter circuit composed of two IGBT. When clicking on the continuous operation, connect the PWM output from the micro controller to the oscilloscope and then it can be observed to produce the waveform of the PWM control wave.

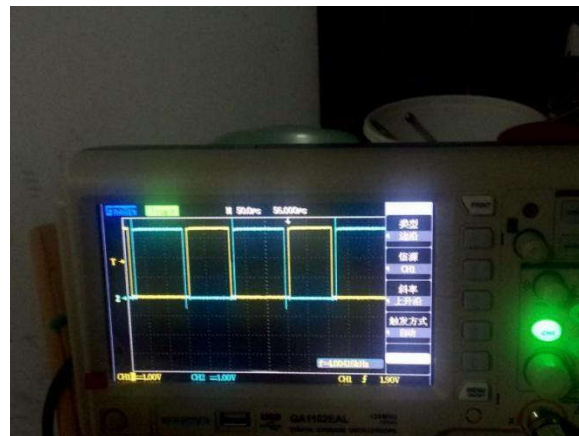

Figure 5 The output waveform

We can see from the diagram in the figure above, the outputs of the two PWM waves are complementary in phase to achieve the requirements of the control circuit. Moreover, it can be seen that there is a clear dead band time when the two PWM waves are in the high-low level

alternation. This also achieves the purposes of protecting circuit and preventing the inverter circuit in the two arms breakovering at the same time which can damage the components. Meanwhile, we can change the frequency of the waveform, duty cycle, dead band time by the operation keys on the MCU. The input clock signal is selected in the 8M crystal, the initial value of the CCR0 is set to 1000 in the program. Therefore, the initial PWM wave frequency can be obtained: $f = 8M / (1000 * 2) = 4KHZ$. It use increase or decrease technical mode, which equals to the value multiplied by two. Then the original PWM waves and the waveform amplified by the TC4424 are shown in Figure 6.

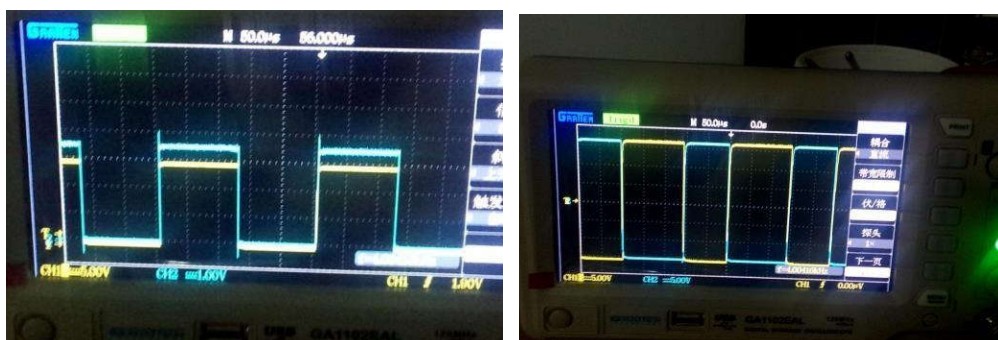

Figure 6 Comparison of PWM wave and amplified waveform

Through the above results can be seen,the inverter circuit can work properly.It has basic ally achieved the desired objectives.The frequency, duty cycle, dead band time can also be adjusted through the physical buttons on the microcontroller. Based on the design of high frequency inverter power supply control design as described in this article,SCM control circ uit can be programmed by software easily, At the same time, the generation of dead band ti me can be realized when the waveform is generated.In this way, the protection of electronic devices in the circuit and the hardware circuit can be further realized. So that the entire cir cuit will work more secure.

5.Conclusion

After the selection of topics,data access, program design,circuit connection and the final download and debugging,this paper has basically reached the expected objectives of the project. This is the realization of high-frequency power supply control based on MSP430.SCM as the core of control compared to other control mode has some advantages:

1. Replaced hardware circuits by software,reduced cost , power consumption and the volume is reduced to some extent
2. I/O port with free configuration , we can modify the function at any time.The program can be improved according to requirements , and can't be eliminated too early.
3. Digital display can be easier to communicate with the operation.

However, controlled by the micro controller also exists some shortcomings, which needs to be improved.Because of the limitations of SCM, the frequency and the resolution of the PWM control wave it produces have some limitations.In addition,the PWM wave generated by SCM can't be used to drive IGBT.We need to add a driver module in the middle of the PWM control wave amplification to achieve the degree of driving IGBT. Due to the limited knowledge of experimental materials and personal skills,there is a certain gap between the technical indicators and the actual parameters.We will strive for improvement in future research.

Reference

- [1]. Xie Yunyan. Design and development of power 30kVA digital inverter emergency power supply [D]. Electronic Science and technology, Hunan University, 2011
- [2]. Wang Juan. Design of three phase sine inverter power supply based on [D]. FPGA communication and information system of North China Electric Power University. 2009
- [3]. Chen. Design of high efficient emergency power supply structure for ships [D]. Zhejiang Ocean University, 2013
- [4]. cable: Digital single-phase inverter control technology research of Heilongjiang Institute of Science and Technology [D]. power electronics and power transmission.
- [5]. Baohong. Principle and application of MSP430 microcontroller: MSP430F5xx/6xx MCU entry, improve and development. Electronics Industry Press,.2014
- [6]. Li Pingfeng. The overview of modern power electronics technology [J]. mechanical management development. 2012