

NONDESTRUCTIVE INSPECTION TECHNIQUES FOR ROCKET MOTOR CASINGS

Karthik Bujuru (MS)*

*Corresponding Author:

1. Abstract

Non-destructive techniques (NDTs) as an inspection methodology have an obvious advantage of not irreversibly damaging the samples for the host material's structural integrity evaluation. Although the information regarding various conventional NDTs is well documented in the scientific literature, this article's objective is to review each of the method as it pertains to evaluating quality of critical subsystems such as rocket motor casings. NDTs such as liquid penetrant testing, ultrasonic testing, radiographic testing are reviewed along with relatively novel acoustic emission technique. The article also discusses specific reasons for why acoustic emissions technique is particularly well suited for real-time monitoring of rocket motor casings and its impact on revolutionizing the quality assurance of crucial infrastructure.

Keywords: *NDT, Acoustic Emission Inspection, Ultrasonic Inspection, Radiographic Inspection, Liquid Penetrant Test*

2. INTRODUCTION

The importance of the choice of materials, their design and quality control for critical subsystems like rocket motor casings is detailed in our previous publication[1]. The high strength maraging steels are fracture prone which requires a fracture-based design approach in addition to the strength-based design[2]. The chosen fabrication method also induces defects that are inevitable. For quality control of structures that are designed using this approach fracture control becomes the focal point of design assurance. Hence, the appropriate strategy for quality control is to allow those defects that are identified to be safe than trying to eliminate them completely from a cost standpoint.

This paper focuses on quality control of rocket motor casings using non-destructive testing to evaluate material integrity. The non-destructive techniques are methods to evaluate material for surface or internal flaws or metallurgical condition without destruction of the material impacting its suitability for service[3]. There are several non-destructive techniques (NDT) based on the material and its intended application. In this article we will discuss some of the most common NDTs that are used for material evaluation in rocket motor casings quality control.

3. Non-destructive Inspection Techniques

NDT is an effective tool to identify manufacturing defects of rocket motor casings and helps in conducting repairs that need to be addressed before the start of their service period. Traditionally, radiographic testing complemented with ultrasonic testing is an effective tool for detecting flaws in welding and heat affected zones[4]. These methods are used to define type, geometry, and orientation of defects in welds and heat affected zones. The drawback of traditional NDTs for rocket motor casing inspection is that these techniques are not able to conduct online monitoring of dynamic behavior of structures under load. Defects such as tight cracks can sometimes go undetected using these techniques due to either inspection method limitations or operator fatigue. A novel NDT method using acoustic emissions is used for dynamic, real-time evaluation of rocket motor structures under load[5]. Some defects that go undetected using traditional techniques are identified using acoustic emissions NDT. This NDT method, although gaining popularity in recent times, is also not very well understood for its application in material evaluation of critical subsystems such as rocket motors. Therefore, in this section we will provide an overview of traditional NDTs, their application method, discuss their advantages and drawbacks before concluding with detailed discussion on acoustic emissions as an NDT method.

3.1. Liquid Penetrant test

3.1.1. Overview:

In the liquid penetrant inspection method, a bright colour dye is applied to the surface of material under inspection to detect surface flaws. The dye contains fluorescent particles that is drawn into cracks and flaws on the surface that are as small as $1\mu\text{m}$, and under UV light these discontinuities become apparent exposing the material defects[6].

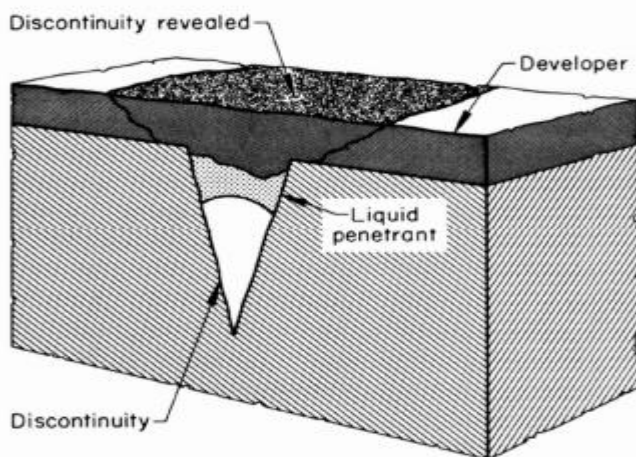

Figure 1 Liquid Penetrant Test

3.1.2. limitations:

Some of the limitation of liquid penetrant test include

- Discontinuous or flaws need to be on the surface to get detected
- Corrosion effects of inspection dye on the substrate material
- Non-suitability of the method for low density powder metallurgy parts

These drawbacks limit the use of this NDT on only certain types of applications where the defects or other material irregularities only present on the surface can be detected.

3.2. Ultrasonic Inspection

3.2.1. Overview:

Ultrasonic Inspection is the most widely used NDT and is used for detection and characterization of different kinds of defects such as cracks, laminations, shrinkage cavities, bursts, flakes, pores, disband and corrosions. In this technique high frequency sounds waves transmit through the material with some attendant loss of energy and reflects back at the interface

of a defect[7]. These reflected waves are then analysed for identification of flaws. The degree of reflection at the defect interface defines the size and location of the defect within the host material. Most ultrasonic inspections are conducted at frequencies ranging from 0.1-25 MHz and they detect flaws by monitoring one or more of the following aspects

- Reflection of sound from interfaces consisting of material boundaries or discontinuities within the metal itself
- Time of transit from exit of the sound wave from transducer, through the test piece and back to the entrance point of the transducer.
- Attenuation of sound waves due to absorption and scattering with in the test piece
- Features in the spectral response for either transmitted or reflected signal.

3.2.2. Advantages:

Some of the advantages of the ultrasonic inspection that sets it apart from the rest of the NDTs are below

- Superior penetrating power of the sound waves which allows for detection of flaws that are buried deep in the part
- High sensitivity that allows for detection of extremely small flaws
- Greater accuracy than other NDTs in identifying position of internal flaws, and characterizing their size, orientation, and shape.
- Requirement of only one surface of the inspection material to be accessible.
- Portability and ability to digitally process the outputs to characterize defects and identify material properties.

3.2.3. Disadvantages:

Some of the drawbacks of this inspection method include

- High technical nature of the inspection procedures and their development
- Difficulty of inspecting non-homogenous parts
- Material defects present immediately next to the surface are difficult to detect
- Complex test setup requiring specialized equipment for effective transfer of energy between transducers and parts being inspected, need for equipment calibration and flaws characterization.

3.2.4. Ultrasonic Inspection Techniques

- Pulse-echo technique: This is the most commonly used inspection technique, primarily used for detection of echoes reflecting back from the defects in the material confirming the presence and location of defects.
- Transmission technique: This method is more basic for its use in detection of presence of defects or otherwise. The sound waves when transmitted through a material containing defects are attenuated to a greater degree compared to those that transmitted through material without defects. This method cannot be used to detect flaw depth.
- Angle Beam technique: This method is used for testing welds, sheets and plate material for detection and precise location of flaws. The sound beam enters the test material at an angle and propagates by successive reflections by the specimen boundary until a flaw is encountered. The linear distance between two reflecting points is called skip distance, and moving the search unit back and forth between one-half skip distance and one-skip distance from an area of interest allows for precise location of flaw along with its depth and size.

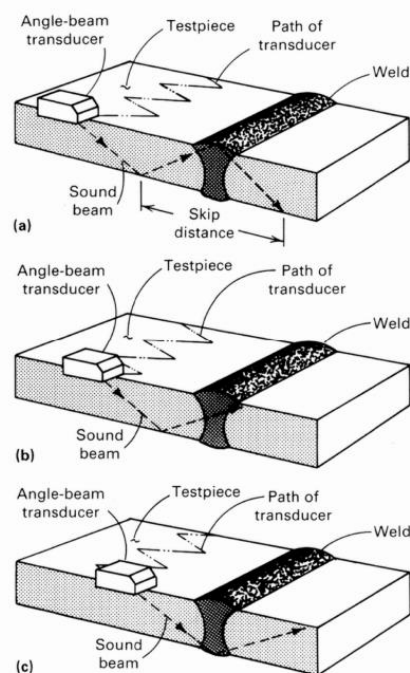

Figure 2 Angle Beam Technique

3.3. Radiographic Inspection:

This inspection technique uses radiology method to produce two-dimensional, plane view images from the unabsorbed radiation by the defects or discontinuities in the material. In a film radiographic technique, a latent image is formed on a sheet of film exposed to unabsorbed radiation passing through the test piece.

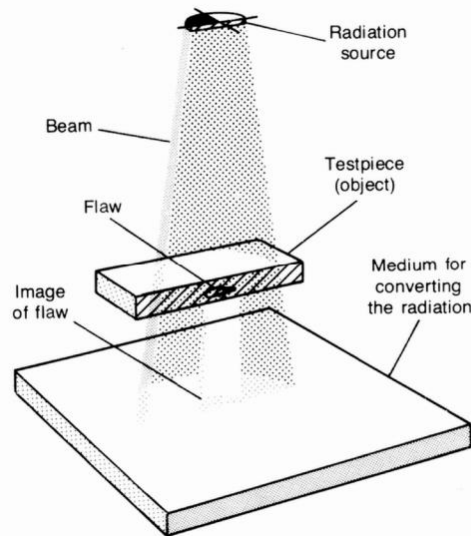

Figure 3 Basic Radiographic Inspection

In another type of inspection called radioscopy, the unabsorbed radiation from the material defect is converted to an electronic signal that is displayed as a 2-dimensional image on a viewing monitor[8].

3.3.1. Inspection Technique:

The radiation source is directed towards the test piece at right angles to surface allowing for the energy beam to pass through the material with defects. The intensity of the image representing unabsorbed radiation is proportional to the size of the defect thus allowing for direct visual quantification of the defect. The radiographic inspection technique is used to inspect flat plates, curved plates, weldments, etc.

- Radiographic Inspection of Flat plates: Flat plates are usually an integral part of more complex rocket motor casings assembly or component and are inspected with the beam directed perpendicular to the surface of the plate. For minimum distortion, maximum sensitivity, and resolution the beam needs to penetrate the shortest dimension. To inspect large areas, a series of radiographs with each one overlapping the area of coverage of the adjacent radiographs is more effective than a single large radiograph.
- Radiographic inspection of curved plates: To radiograph curved plates, the image conversion plane is ideally shaped to conform to back surface of the plate being inspected. If the curved plate has its convex side facing incident radiation, it is identified that making smaller multiple smaller radiographs is ideal to minimize distortion. Similarly, if the concave side of the curved plate is facing the incident radiation, a distortion free image can be obtained if the radiation source is placed at the center of the curvature.
- Radiographic inspection of weldments: Weldments are usually inspected using this inspection technique to verify quality of welds and the base metal only in the heat effected zone. For butt joints, the incident beam is directed normally to the surface of the adjacent plates for the best results. While for other types of joints such as T and Lap, the central beam is usually inclined to both adjacent legs to reveal presence of inclusions, porosity, and shrinkage.

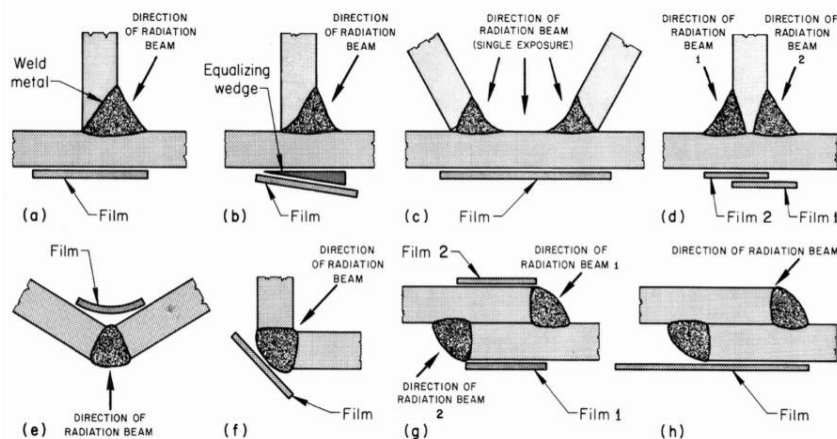

Figure 4 Radiographic Inspection for Weldments

3.4. Acoustic Emission Technique

3.4.1. Overview: The transient energy waves produced due to rapid release of energy when a material is stressed are called acoustic emissions. These emissions are captured by the piezoelectric sensors placed on the test article, and then analyzed by the specialized software to quantitatively assess the location, type and orientation of the defect based on signal parameters such as amplitude, event duration, number of hits, hit rate etc.

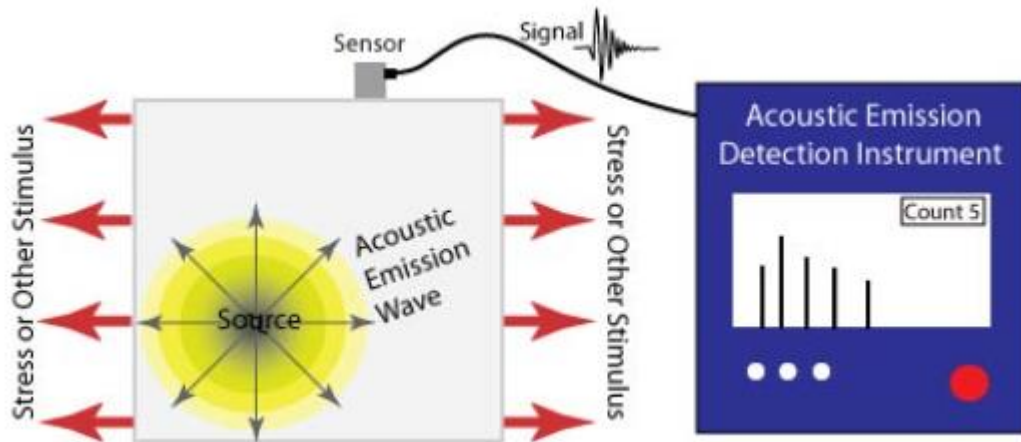

Figure 5 Acoustic Emissions Inspection Schematic[9]

Acoustic emissions inspection technique is growing in popularity specifically for structural integrity evaluation of rocket motor casings due to its unique ability to conduct real time monitoring of the structures concurrently while under load. It is widely reported that this inspection technique was able to detect flaws in the system that escaped the conventional NDTs[10].

Most of the acoustic emission sources can be distinguished by their acoustic emission signatures characterized by magnitudes of their amplitudes, event count, hit count and rates etc.

3.4.2. Acoustic Emission System Setup: A typical AE system could range from single channel single purpose device to multi-channel multi-processing system. The test setup schematic shown in Figure 6 showcases one or more AE sensors, a preamplifier per each channel and each of which are connector to an AE processor after routing through signal conditioners. As the material under inspection gets loaded, it generates acoustic emissions that pass-through noise filters, pre-amplifiers, signal conditioners and then an AE processing system that correlates the signal outputs to the activity detected in the material. The outputs can illustrate the location of acoustic activity within the structure, magnitude and type of defects based on signal parameters.

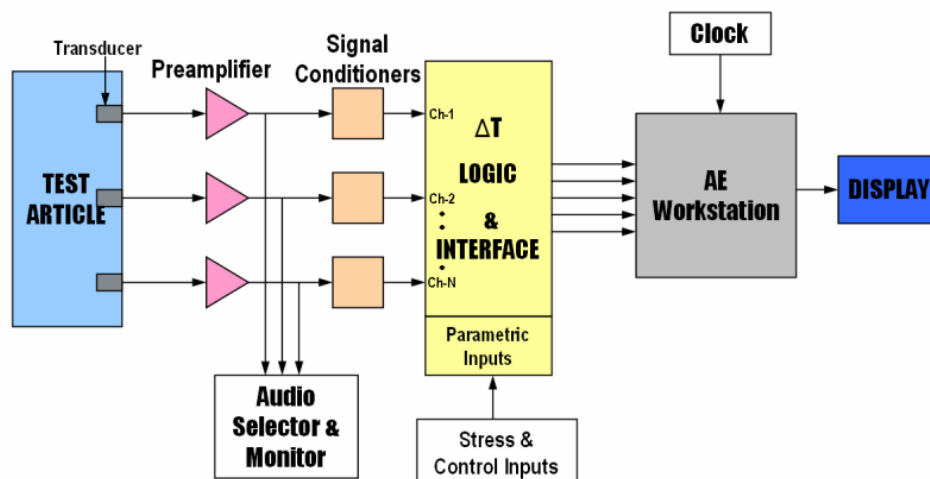

Figure 6 Acoustic Emissions Inspection Process flow

3.4.3. Rocket Motor Evaluation by Acoustic Emissions Testing: The overall structural integrity of rocket motor casings can be quickly evaluated by using the specific pressure cycles and pressure holds stipulated by the standards and by evaluating the felicity graph outputs. The felicity ratio (FR) is defined as ratio between the applied load at which acoustic emission reappears during next load application to the previous maximum load applied. The structural integrity of the rocket motor casing is defect less as FR approaches 1, and conversely the structure is known to have defects for any other FR numbers.

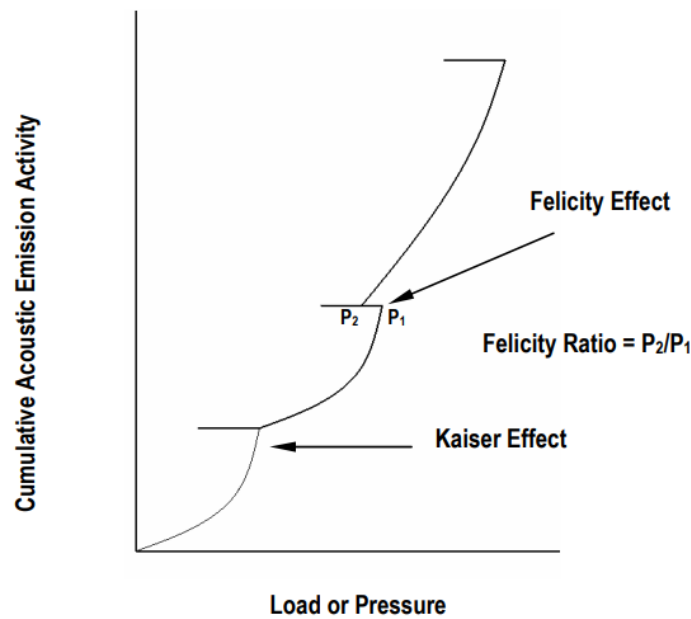

Figure 7 Felicity Effect

Other evaluation criteria for rocket motor structural integrity are using acoustic emission signal parameters like hits. Monitoring hits during pressure hold periods reveals vital information about the quality of structures being inspected. Sources are classified based on their acoustic activity (hits) and intensity (peak amplitudes). A source is considered to be active (source 2) if its AE activity continues to increase with increasing or constant load. It is considered to be critically active (source 3) if the rate of change of its AE activity with respect to load continuously increases with increasing pressure or with time under constant pressure.

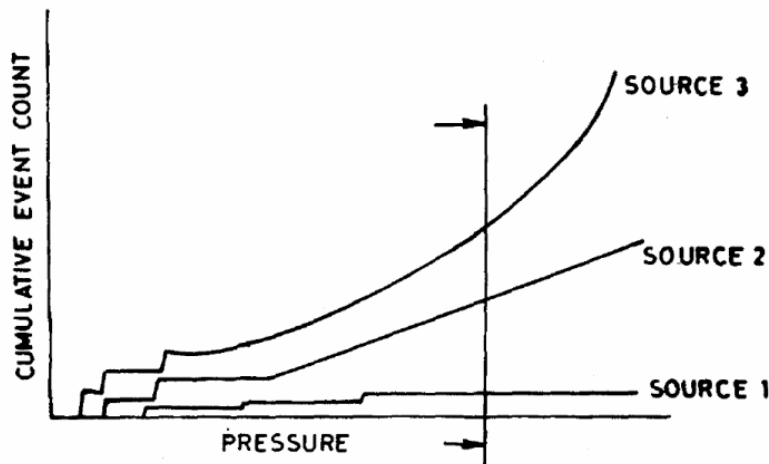

Figure 8 Acoustic Emission Source Classification

4. Conclusion

The article reviews the various types of non-destructive techniques as it pertains to quality assessment of critical infrastructure like rocket motor casings. An inspection technique may be chosen considering the difficulty of test setup, the sub-system being inspected, advantages and disadvantages of that method. The article also delves into the test setup, and application of popular conventional techniques like ultrasonic inspection, and concludes with information on acoustic emissions inspection technique, and the reasons for its growing popularity for advantages of real time monitoring of rocket motor's structural integrity evaluation.

5. References

- [1]. K. Bujuru and M. V, "Failure Prediction using Acoustic Emissions and Artificial Neural Networks," *INTERNATIONAL JOURNAL OF ENGINEERING RESEARCH & TECHNOLOGY (IJERT)*, vol. 12, no. 07, Aug. 2023.
- [2]. P. K. Behera, "Quality Assurance of Aerospace Pressure vessels by Acoustic Emission Examination techniques," *Journal of Aerospace Quality and Reliability*, vol. 3, no. 1, pp. 59–68, 2007.
- [3]. S. K. Dwivedi, M. Vishwakarma, and Prof. A. Soni, "Advances and Research on Non-Destructive Testing: A Review," *Mater Today Proc*, vol. 5, no. 2, pp. 3690–3698, 2018, doi: 10.1016/j.matpr.2017.11.620.
- [4]. R. G. Liptai and C. A. Tatro, "Acoustic emission techniques in nondestructive testing," California Univ., 1973.

- [5]. A. A. Pollock, "Acoustic emission - 2," *Non-Destructive Testing*, vol. 6, no. 5, pp. 264–269, Oct. 1973, doi: 10.1016/0029-1021(73)90074-1.
- [6]. M. Gupta, M. A. Khan, R. Butola, and R. M. Singari, "Advances in applications of Non-Destructive Testing (NDT): A review," *Advances in Materials and Processing Technologies*, vol. 8, no. 2, pp. 2286–2307, Apr. 2022, doi: 10.1080/2374068X.2021.1909332.
- [7]. ASM, "Fundamentals of Ultrasonic Inspection[1]," in *Nondestructive Evaluation of Materials*, ASM International, 2018, pp. 155–168. doi: 10.31399/asm.hb.v17.a0006470.
- [8]. H. Kriesz, "Radiographic ndt—a review," *NDT International*, vol. 12, no. 6, pp. 270–273, Dec. 1979, doi: 10.1016/0308-9126(79)90086-5.
- [9]. Iowa State University- Center for NDE, "Acoustic Emission Testing," <https://www.nde-ed.org/NDETechniques/AcousticEmission/index.xhtml>.
- [10]. K. Bujuru and M. V, "Acoustic Emissions Signal Parameter selection for training Artificial Neural Network," *International Journal of Engineering Research & Technology (IJERT)*, vol. 12, no. 09, Sep. 2023